

LASER GAME

INSTRUCTIONS

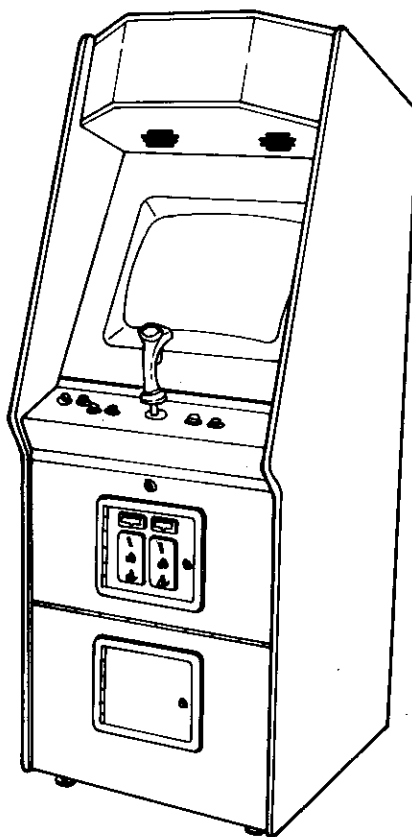

*LEAVE
switch
sheet
e*



	DATA EAST USA, INC.
	470 Gianni Street, Santa Clara, CA 95050
	Telephone: (408) 727-4490
	Toll Free: (800) 538-5129
	Telex: 172163 DATA EAST SNTA

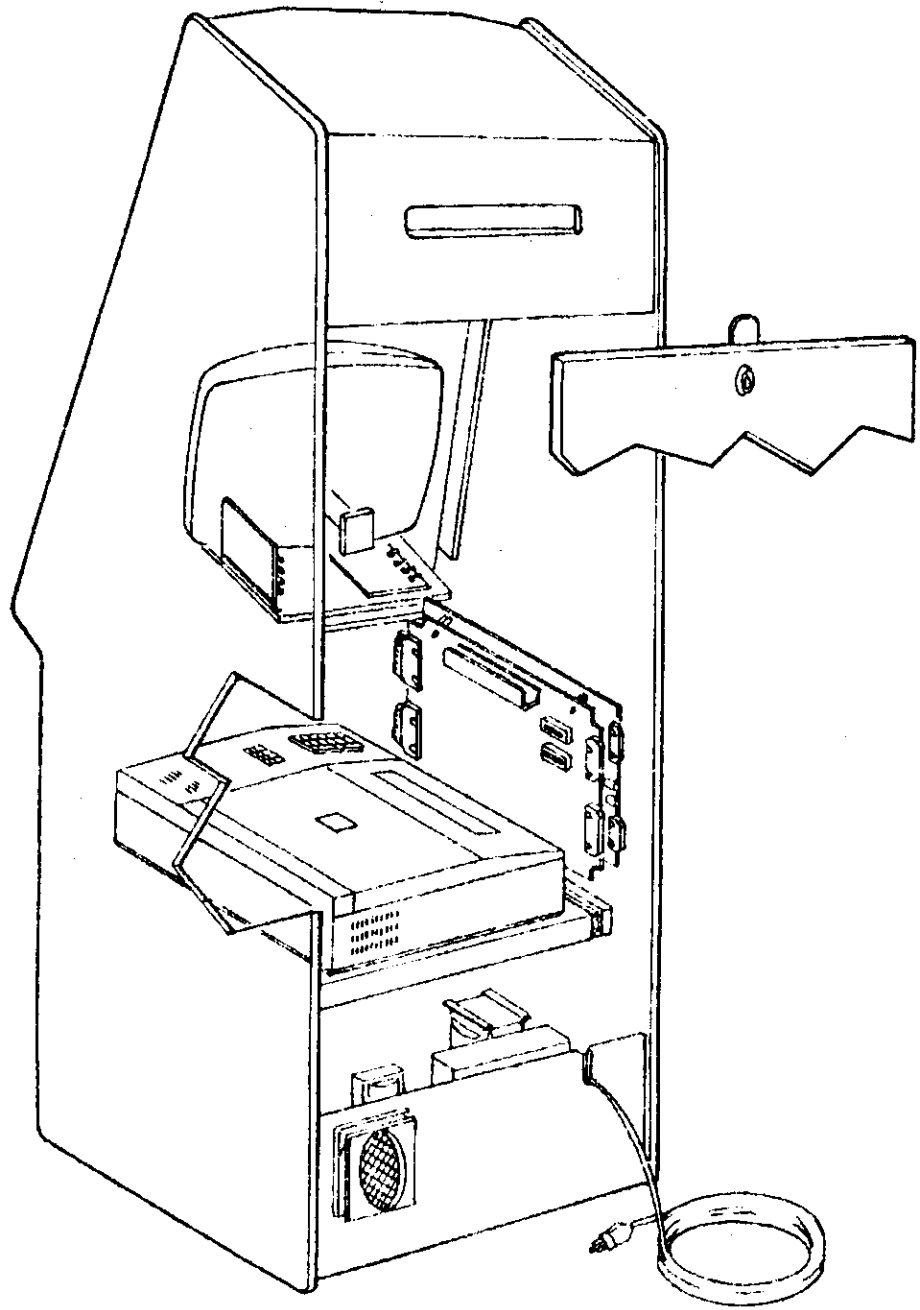

TABLE OF CONTENTS

<u>Page</u>	
1.	Preliminary Information
6.	Routine Maintenance
9.	Audio Adjustments
10.	Marquee Lamp Replacement
11.	Option Switch Settings
12.	Control Panel Parts List
13.	Self Test Diagnostics
14.	Self Test Flow Chart
18.	List of Schematics

PRELIMINARY INFORMATION

General Description

The Data East Laser Disc Video Game System comprises a laser disc generated video background with computer (P.C.B.) generated game play characters. The video signals from the laser disc are combined with the video signals from the P.C. Board on an auxiliary video board that is part of the TV monitor assembly. Through this arrangement the PCB superimposes interactive game play characters over the moving laser disc background. This allows the game player to use the joystick and action buttons to control the behavior of the game play characters.

THE GAME SET-UP

Installing the Video Disc Player

Remove Video Disc Player from the packing container. **SAVE** the shipping container for future packaging. Inspect the Video Disc Player for any physical damage.

The shipping screw must be removed before operating the Video Disc Player. Turn the shipping screw in a counter clockwise direction with a coin or similar object until the screw is loose.

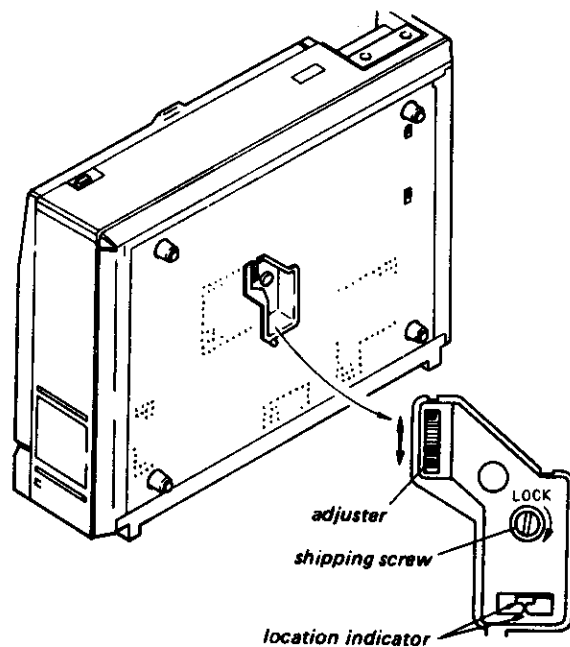

Set Player on the edge of the Video Disc Player shelf with the front of the player facing to your right.

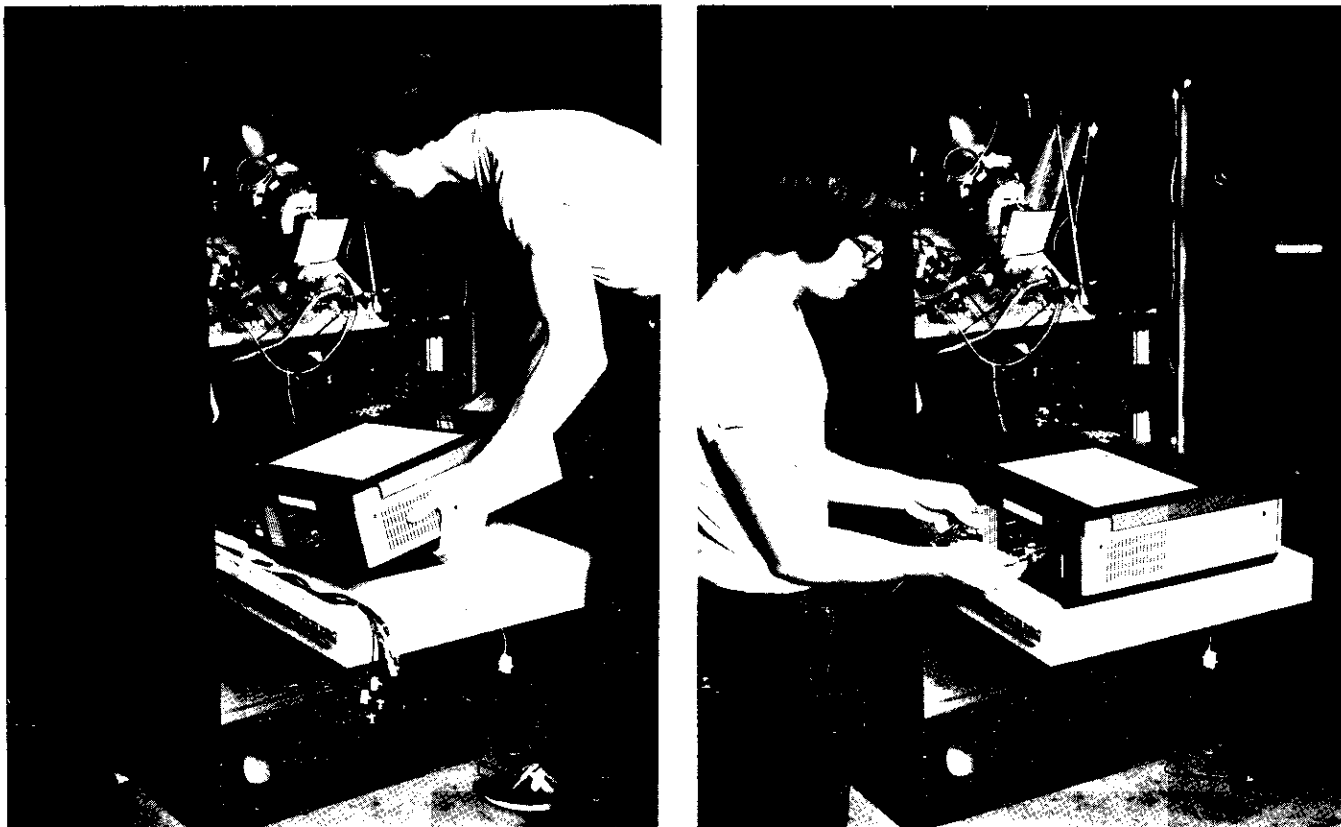

Place Video Disc Player feet in the recesses provided and refer to Figure 1 for connection procedure.

CAUTION

THE VIDEO GAME CABINET SHOULD NOT BE MOVED WITH THE VIDEO DISC PLAYER INSIDE. Remember that the player is a delicate electronic instrument. Before moving the cabinet, be sure to lock down the laser shipping screw, then remove the player from the machine. This prevents damage to the delicate mechanism.

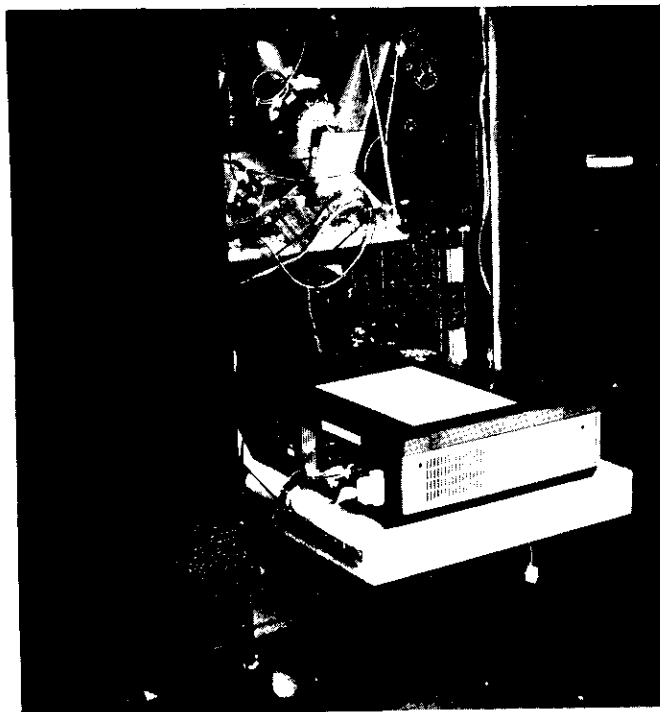

CONNECTING VIDEO DISC PLAYER

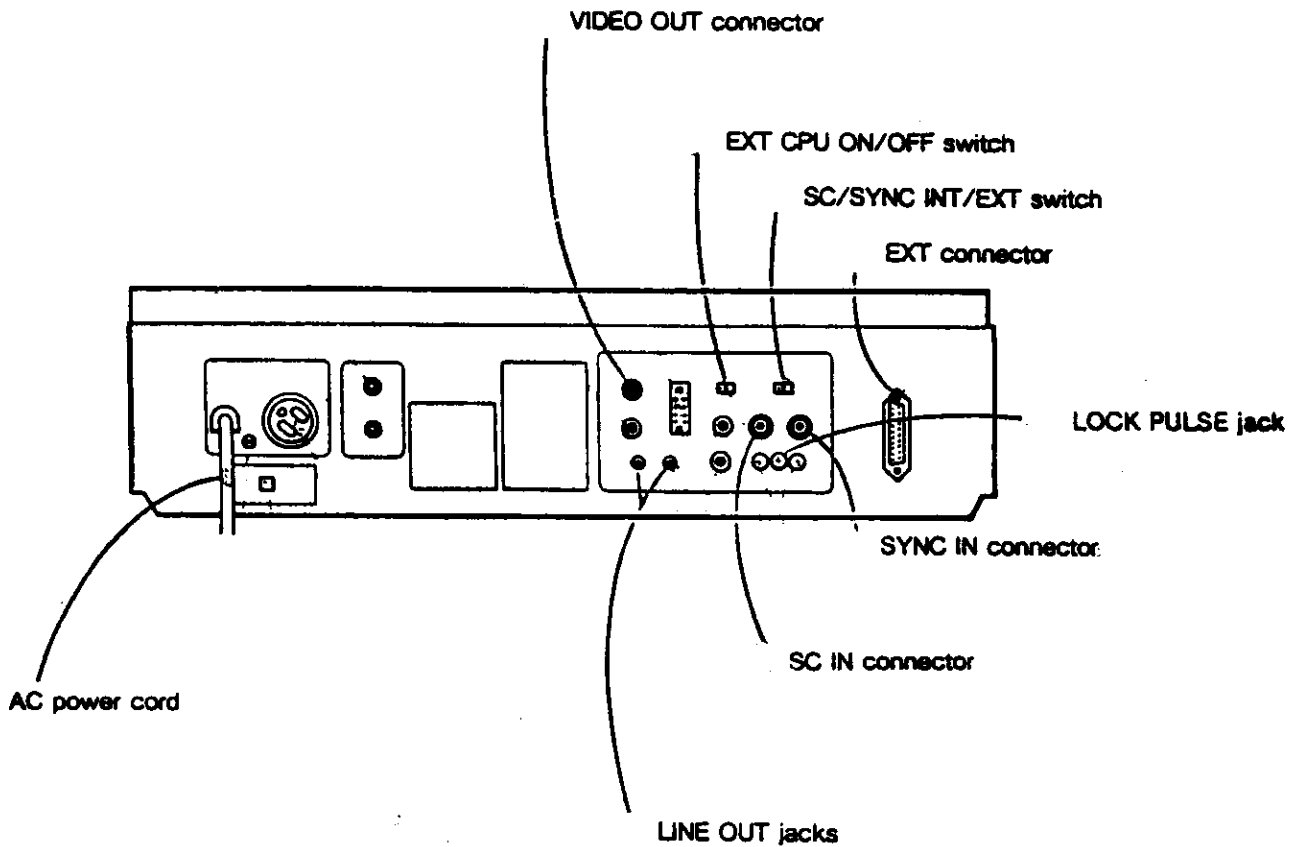

FIGURE 1

Connect the gray ribbon cable to the connector marked EXT on the Disc Player (VDP)

Connect the remaining cables per labels.

Verify that the following connectors are hooked up:

- VIDEO OUT (BNC)
- SYNC IN (BNC)
- SC IN (BNC)
- LOCK PULSE (MINIATURE PHONE JACK)
- LINE OUT (CHANNEL 1 LEFT, CHANNEL 2 RIGHT)

Verify that the EXT CPU is in the ON position and that the SC switch is in the EXT position.

To Install the Video Disc

To Open and Close the Disc Compartment Lid

1. Plug in the game ac Power Cord
2. Plug the ac Power Cord into the outlet on the drawer
3. Press the POWER Button
4. Press the OPEN Button. The lid will unlock and lift up slightly.
5. Lift up the lid all the way. Be careful not to force the lid beyond its normal open position.

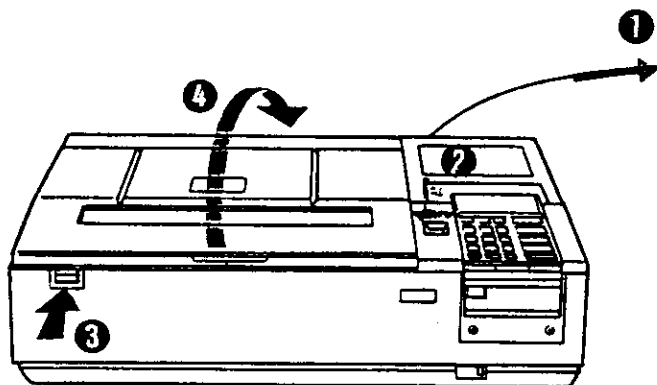

To Close

Push the lid down firmly so that the latch locks securely.

If the lid does not open:

1. Turn the power off
2. While pressing the OPEN Button, press the POWER Button again.
3. If the lid still does not open, contact your Data East Service Department.

Remove the Cap Over the Objective Lens

A cap has been put on the objective lens at the factory to protect the lens from damage and dust.

Open the disc compartment lid and remove the cap.

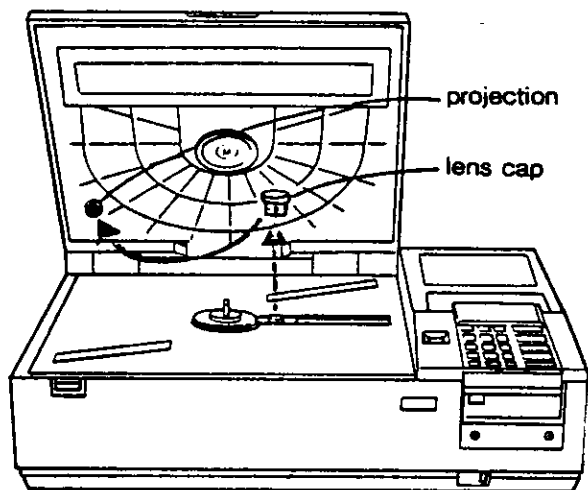

The lens cap should be saved for later use when the player is shipped again or is not in use for an extended period of time. Save the cap by putting it over the projection on the lid.

To Insert and Remove the Video Disc

To Insert:

1. Open the disc compartment lid
2. Place the disc with the Program label down install it to the center wheel firmly.
3. Close the lid.

The disc will start rotating. The STANDBY Lamp will blink for several seconds to show that the player is ready to play.

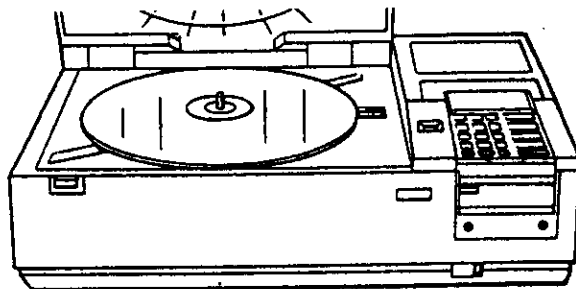

To Remove:

1. Press the OPEN Button when you want to stop playing the disc no matter what mode the player is in. The disc will stop rotating and the lid will unlock and lift slightly.
2. Lift the lid all the way.
3. Remove the disc, holding it by the rim.
4. Close the lid

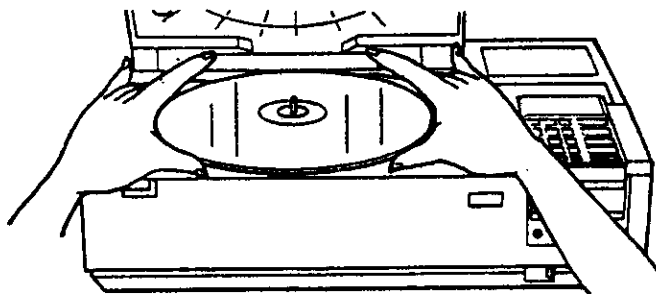

ROUTINE MAINTENANCE

A. VIDEO DISC PLAYER

The life of the Video Disc Player is affected extensively by operation ambient conditions. Always ensure that the player is provided with adequate ventilation.

On a weekly basis, remove the disc and wipe any dust using a clean soft cloth. Also dust the disc carrier and use a soft, lint-free cloth to dust the objective lens.

The Video Disc Player should be submitted to a qualified technician every 2500 operating hours for routine maintenance.

B. MONITOR ADJUSTMENTS

NOTE: Monitor adjustments are somewhat interactive. Procedure may need to be repeated.

1. Degauss monitor using a hand held degausor or by depressing the erase button on the power panel.
2. On neck PCB, turn R, G and B controls full counter clockwise (all the way off).
3. Using the self check diagnostic procedure, call up red color bars from the PCB. Adjust the red adjustment on main monitor board until the 6th bar just becomes visible.
4. While still in self check mode, depress the "Barrier" button on the front control panel to get green color bars. Adjust the green adjustment on the main monitor board until the 6th bar just becomes visible.
5. Depress the "Barrier" button again to get three blue color bars. Adjust the blue control on the main monitor board until the third bar is just barely visible.
6. Depress the "Barrier" button again and a totally white screen should be visible. It may be necessary to readjust the blue control slightly to get the whitest possible screen.
7. Depress "Barrier" button repeatedly until grey reference bars (step 16 of monitor adjust diagnostic) are obtained. Use controls on Video Chroma PCB to adjust screen so that the 9th bar is white.
8. Call up the blue border screen (step 5 of monitor adjust diagnostic). Adjust height to extend to the top end of the picture tube. Adjust width so that there is less than one inch of picture tube beyond the blue border.
9. Repeat steps one through eight as necessary.

REPRESENTATIVE WAVEFORMS

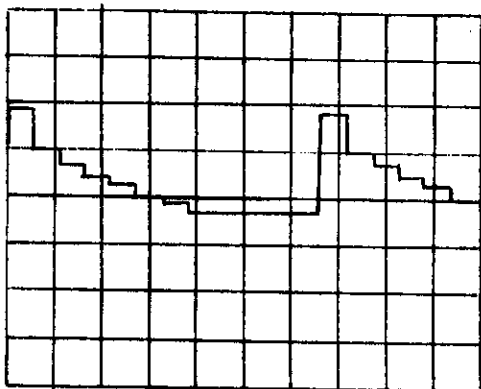

Factory Diagnostic Mode
Video Pattern No. 1 (RED Stairstep)
TEST POINT: Z401 pin 7
SETUP:
Vert - AC, 0.2V/div
Sweep time: 10 us/div

For Video Pattern No. 2 (Green Stairstep)
use Test Point: Z401 pin 5

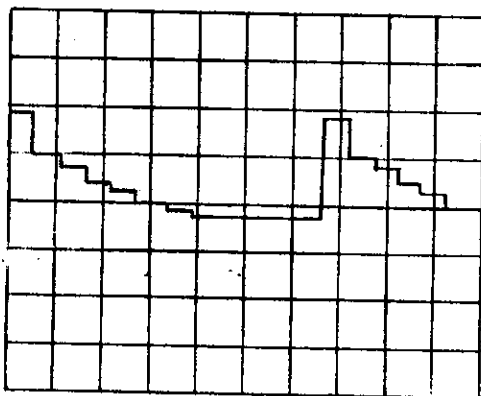

Factory Diagnostic Mode
Video Pattern No. 1 (Red Stairstep)
TEST POINT: TP 4
SETUP:
Vert - AC, 0.2V/div
Sweep time: 10 us/div

For video Pattern No. 2 (Green Stairstep)
use test point: CN3-G

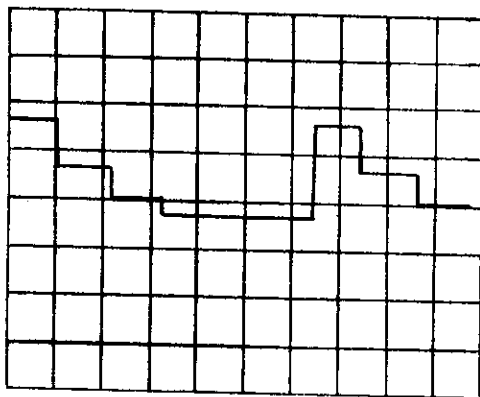

Factory Diagnostic Mode
Video Pattern No. 3 (BLUE Stairstep)
TEST POINT: Z401 pin 3
SETUP:
Vert - AC, 0.2V/div
Sweep time: 10 us/div

V I D E O C H R O M A B O A R D
R E P R E S E N T A T I V E W A V E F O R M S

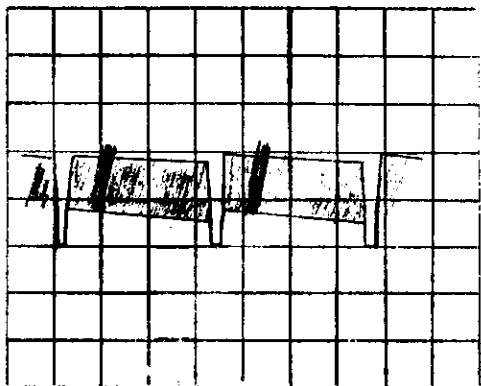

Factory Diagnostic Mode
Video Pattern No. 16 (White Stairstep)
TEST POINT: TP-4
(also at CN 3-G & CN 3-B)

SETUP:
Vert - AC, 2 V/div
Sweep time: 5 ms/div

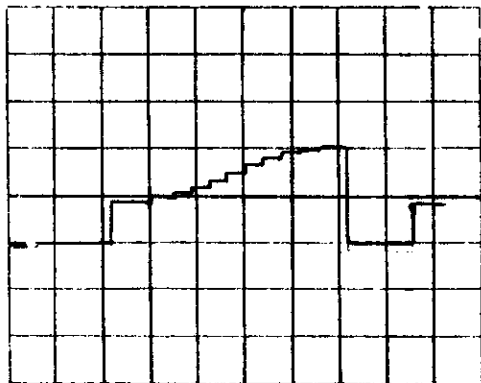

Factory Diagnostic Mode
Video Pattern No. 16 (White Stairstep)
TEST POINT: TP-4
(also at CN 3-G & CN 3-B)

SETUP:
Vert - AC, 2 V/div
Sweep time: 10 μ s/div

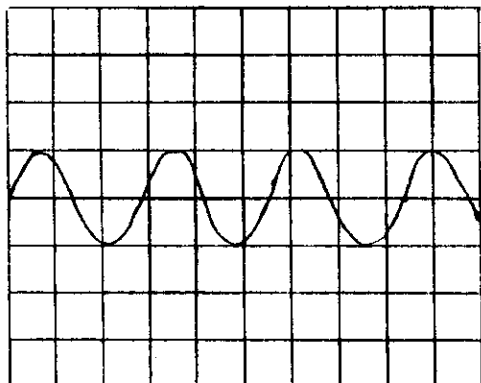

ALL MODES

TEST POINT: TP-2
SETUP:
Vert - AC, 0.5 V/div
Sweep time: 0.2 μ s/div

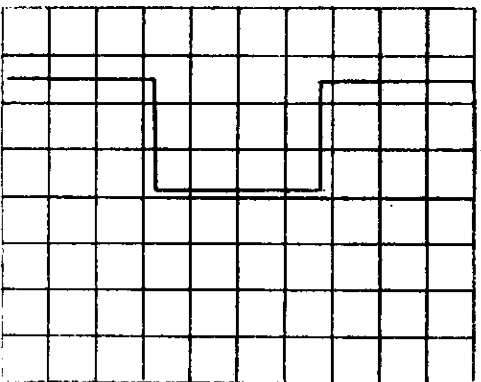

ALL MODES

TEST POINT: CN 2 pin 1
(Lock Pulse)

SETUP:
Vert - DC, 2 V/div
Sweep time: 10 ms/div

AUDIO ADJUSTMENTS

Audio from the Video Disc Player is mixed with audio from the PCB. It is important to adjust audio levels in the following order: (See Figure below)

First adjust VR-1 (main audio adjust control on VDO-2) to the mid position. With proper audio signal coming from the Video Disc Player, adjust VR-2 (L) & VR-3 (R) for a pleasing balance with the audio from the PCB.

Now adjust the main volume control, VR-1 for the audio output level of your choice.

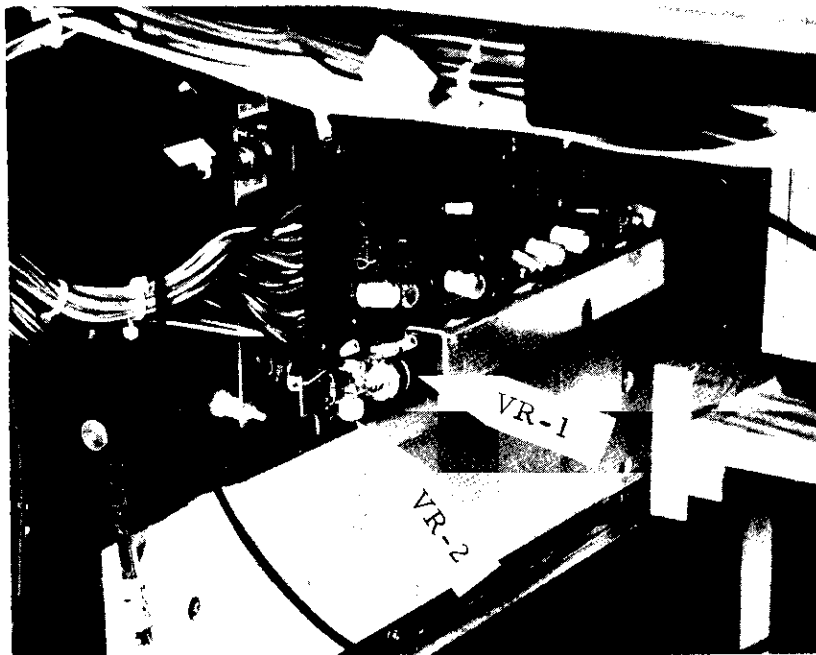

MARQUEE LAMP REPLACEMENT

The marquee lamp/speaker panel can be accessed for servicing by removing the marquee plex retainers and lifting out the marquee plex.

To remove the lamp/speaker tray completely, it is necessary to disconnect the lamp power cable and the speaker cable in the rear of the cabinet.

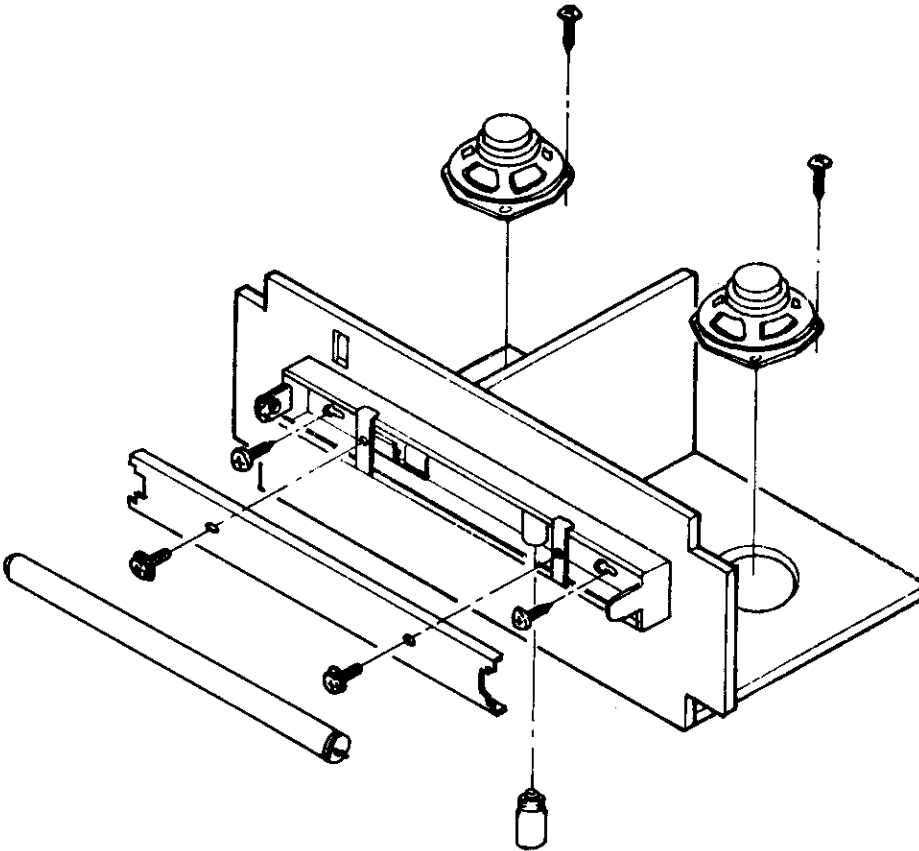

OPTION SWITCH SETTINGS

The following are DIP Switch settings:

DIP SWITCH I

NO.					
1	OFF	OFF	ON	ON	RIGHT COIN SELECTOR
2	OFF	ON	OFF	ON	
COIN	1	1	3	2	
PLAY	1	2	1	1	
3	OFF	OFF	ON	ON	LEFT COIN SELECTOR
4	OFF	ON	OFF	ON	
COIN	1	1	3	2	
PLAY	1	2	1	1	
5	NOT USED				
6					
7					
8					

DIP SWITCH II

NO.					
1	OFF	OFF	ON	ON	NO. BEGA'S PER CREDIT
2	OFF	ON	OFF	ON	
#Begas	3	4	5	6	
3	OFF		ON		CONTINUOUS PLAY MODE
	NO		YES		
4	OFF		ON	ON	BONUS BEGA GAINED AT
5	OFF	ON	OFF	ON	
BONUS	20,000	30,000	50,000	NO BONUS, CONTINUOUS FIRE	
6	OFF		ON		OFF for Factory Diagnostic ON for User Diagnostic
	EASY		DIFFICULT		
7	OFF		ON		
	COCKPIT		UPRIGHT		
8	OFF		ON		DIAGNOSTIC MODE
	PLAY		DIAG.		

CONTROL PANEL PARTS LIST

- | | |
|-------------------------------|---------------------------|
| 1. Heavy Duty Joystick | WICO P/N 15-9431-04 |
| 1a. Control lever, left side | WICO P/N 15-9402 |
| 1b. Control lever, right side | WICO P/N 15-9403 |
| 1c. Trigger | WICO P/N 9418 |
| 1d. Trigger switch | WICO P/N 15-1260-81 |
| 2. Pushbuttons | |
| 2a. RED | WICO P/N 15-9129-01 |
| 2b. BLUE | WICO P/N 15-9172-01 |
| 2c. YELLOW | WICO P/N 15-9169-01 |
| 2d. Button Holder w/switch | WICO P/N 15-0984-01 |
| 2e. Switch only | WICO P/N 15-1241-01 |
| 2f. PAL NUT | WICO P/N 19-0254-01 |
| 3. CONTROL PANEL OVERLAY | DE P/N "Bega Overlay" |
| 4. CONTROL PANEL W/HINGE | DE P/N "Bega Control Pnl" |
| 5. CONTROL PANEL HARNESS | DE P/N |

SELF TEST DIAGNOSTICS

SELF-TEST

The Self-TEST Diagnostic Program is an important function of your Bega Battle Laser game. It is the best way to check for proper operation of the entire game.

OPERATION

Turn the game off before activating the Self-Test, as a safety precaution. The option switches must be adjusted to activate the Self-Test Diagnostics. (refer to the figure below) After the switches are set, turn the game ON. Pushing the SERVICE SW. will cause the game to step through each of its 11 different Self-Tests. To repeat a test hold the Teleport button down, while pushing the SERVICE SW. The Self-Test Diagnostics will continue to repeat through the 11 tests until the option switch settings have been returned to the game mode. Dip switch II position 8 must be off. for game mode and on for diagnostic mode.

OPTION SWITCHES

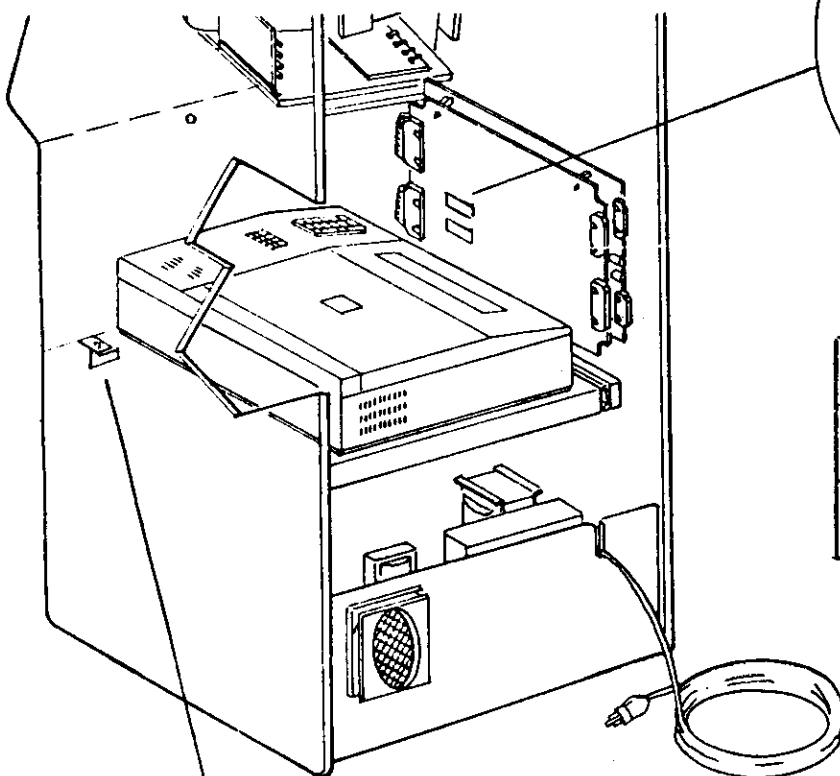
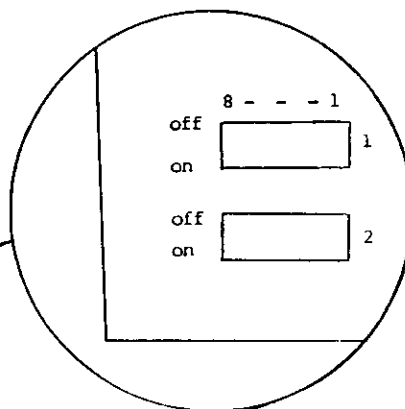

Service Switch

DIP SWITCH II

NO.	POS.	DESCRIPTION
7	OFF	FACTORY DIAG. *
	ON	USER DIAGNOSTICS
8	OFF	GAME MODE
	ON	DIAGNOSTICS

* FACTORY DIAGNOSTICS ARE USED FOR MONITOR ADJUSTMENTS ONLY.

OPTION SWITCHES, SERVICE SWITCH

SELF-TEST FLOW CHART

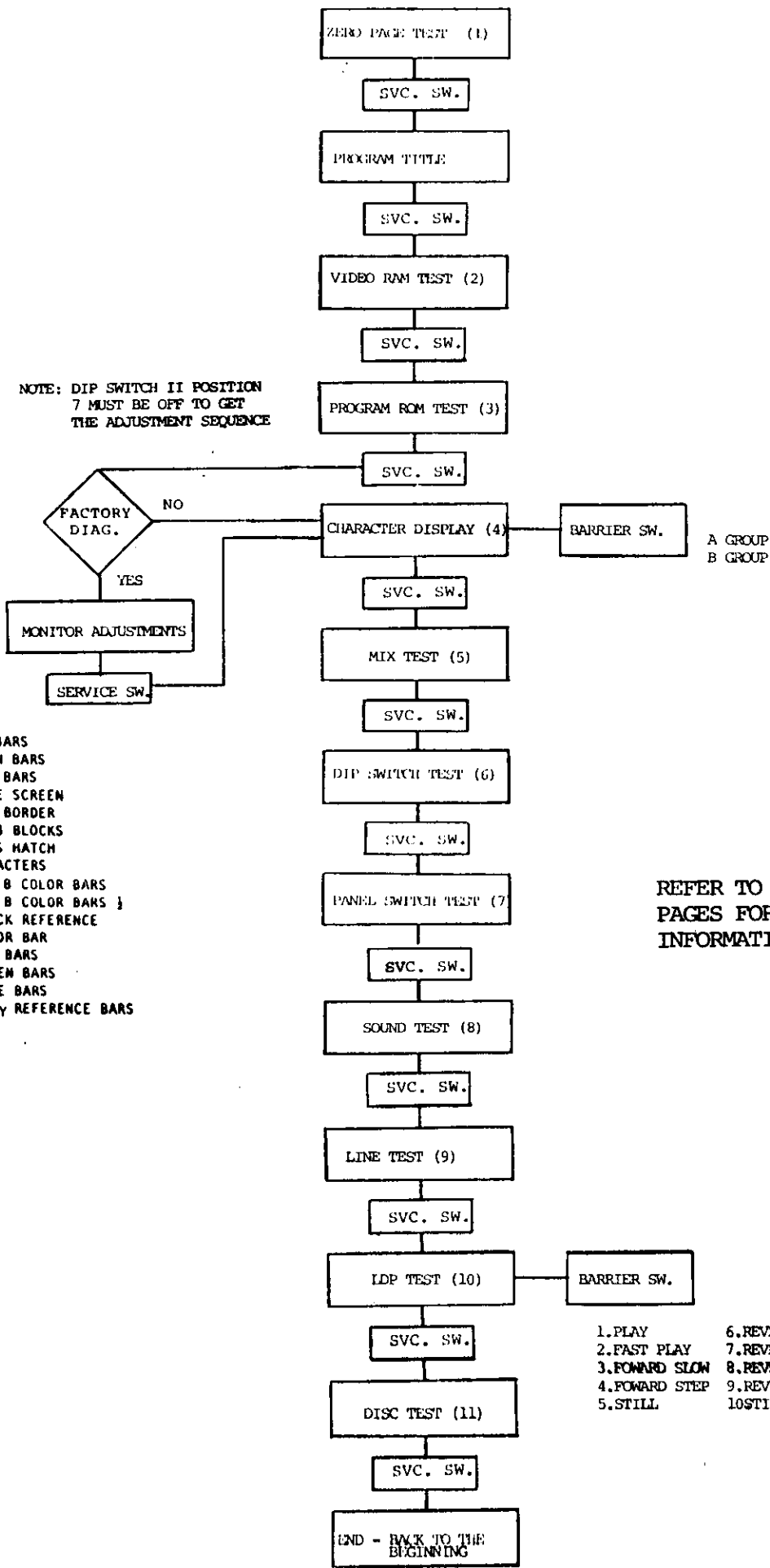

SELF-TESTS

1. ZERO PAGE RAM TEST

This test will automatically take place after the machine is powered up. The Zero Page Ram (Address 0000-0fff) on the VDO-2 Logic Board. Ram locations 3F, 5F are tested.

Pass: If the Zero Page Ram is ok, the test program title will be displayed on the screen.

Fail: If the Zero Page Ram fails the test, the faulty Ram location will be displayed on the screen with the faulty address. If the test fails, continuation of the self-tests will not be possible.

2. RAM TEST

The video RAM (Address 2000-3FFF) and (Address 1800-1837) on the VDO-1 logic board is tested. Several multi-colored screens will quickly be displayed on the screen.

Pass: "OK" will be displayed on the screen.

Fail: The Faulty RAM location will be displayed on the screen.

3. ROM READ TEST

The program ROM (address 4000-Dfff) on the VDO-2 logic board is tested by the check sum process.

Pass: "OK" will be displayed on the screen.

Fail: The faulty ROM location will be displayed on the screen.

4. CHARACTER DISPLAY

The contents of the (A Group) character generator ROM is displayed. By pressing the barrier button, the contents of the (B Group) character generator ROM will be displayed.

Pass: The A Group, and B Group, should be displayed uniformly on the screen.

Fail: Failure is indicated by one or more of the following symptoms:

- 1) White display on the screen
- 2) Verticle lines
- 3) The absence of Red, Green, or Blue.

5. MIX CONTROL TEST

This test has two parts. First, 32 (16 x 16 bit) character blocks are shifted diagonally on the screen, while rotating the character blocks after each pass. Second, 28 character blocks are displayed and shifted against a video disk generated background.

Pass: All block shifts should be smooth.

Fail: Failure is indicated by erratic block shifts or the absence of the correct number of character blocks.

6. DIP SWITCH TEST

This test is helpful in the adjustment of the option switches.

1= Switch ON
0= Switch OFF
X=Switch not in use

7. PANEL SWITCH TEST

The Control Panel, switch input circuitry, and switch wiring are tested.

Pass: When a particular control panel switch is activated, the corresponding block on the screen should be filled.

Fail: A failure is indicated in two possible ways:

- 1) A block filled without a switch activated, a short circuit, possibly a shorted switch.
- 2) A block not filled when a switch is activated, open circuit, possibly a bad switch.

8. SOUND TEST

32 increments of sound will be outputted, fluctuating between the right and left speaker. The Sound Circuitry, Audio Amp, Speakers, and Wiring are tested.

Pass: If the outputted sounds are clear and if End is displayed after the 32 increments, the test is OK.

Fail: Failure is indicated by "READ ERROR" displayed on the screen, the absence of sound or, distorted sound.

9. LDP LINE TEST

The RS 232 Connector and cable for the video disc player communications is tested. This test requires a special purpose socket from the factory. The RS 232 connector is removed from the video disc player and plugged into the special purpose socket. The fire button must be pressed to activate the test.

Pass: "OK" will be displayed on the screen.

Fail: An Error Message will be displayed on the screen.

10. LDP TEST

The Video Disc Player command are tested, forward play, fast forward, forward slow, forward step, still, reverse play, reverse fast, reverse slow, reverse step, still. The Barrier Button is used to select video disc player commands.

Pass: The Video Disc Player should respond to all of the commands.

Fail: If the Video Disc Player does not respond to a command, then the Video Disc Player is bad. Be sure to run the LDP Line Test, because it must work in order for this test to work.

11. DISC TEST

The Video Disc Players search capabilities are tested. Several video screens will rapidly be displayed on the screen. The fire button must be used to activate the test.

Pass: "End" will be displayed on the screen.

Fail: "Error" will be displayed on the screen with the faulty Disc Address.

SCHEMATICS LIST

<u>DWG. NO</u>	<u>NO. SHEETS</u>	<u>DESCRIPTION</u>
K10673	1	Overall wiring diagram
K10674	1	Power Schematic
K10597	2	20 inch monitor (20116DU) schematic
K10678	1	Video chroma PCB schematic
K10679	1	Video chroma PCB component locations
K10671	1	Coin counter drive PCB schematic
K10672	1	Coin counter driver PCB component locations
K10669	1	VDO-1 PCB component locations
K10667	14	VDO-1 PCB schematic diagram SHT 1-DSP control decode SHT 2-DSP control system clock SHT 3-DSP control H-counter SHT 4-DSP control V-counter SHT 5-DSP control A mix cnt SHT 6-DSP control B map ram SHT 7-DSP control A mix cnt SHT 8-DSP control B mix cnt SHT 9-DSP control A line buffer 1 SHT 10-DSP control A line buffer 2 SHT 11-DSP control B line buffer 1 SHT 12-DSP control B line buffer 2 SHT 13-DSP control color control SHT 14-DSP control video out
K10670	1	VDO-2 PCB component locations
K10668-1	10	VDO-2 PCB schematic diagram SHT 1-main CPJ SHT 2-memory and decode SHT 3-DSP control A character SHT 4-DSP control B character SHT 5-coin, SW and I/O SHT 6-RS232-C Interface SHT 7-I/O and sound I/F SHT 8-sound CPU and decode SHT 9-sound memory and generator SHT 10-audio amplifier



LX-2A
 SCHEMATIC DIAGRAM
 K-10673

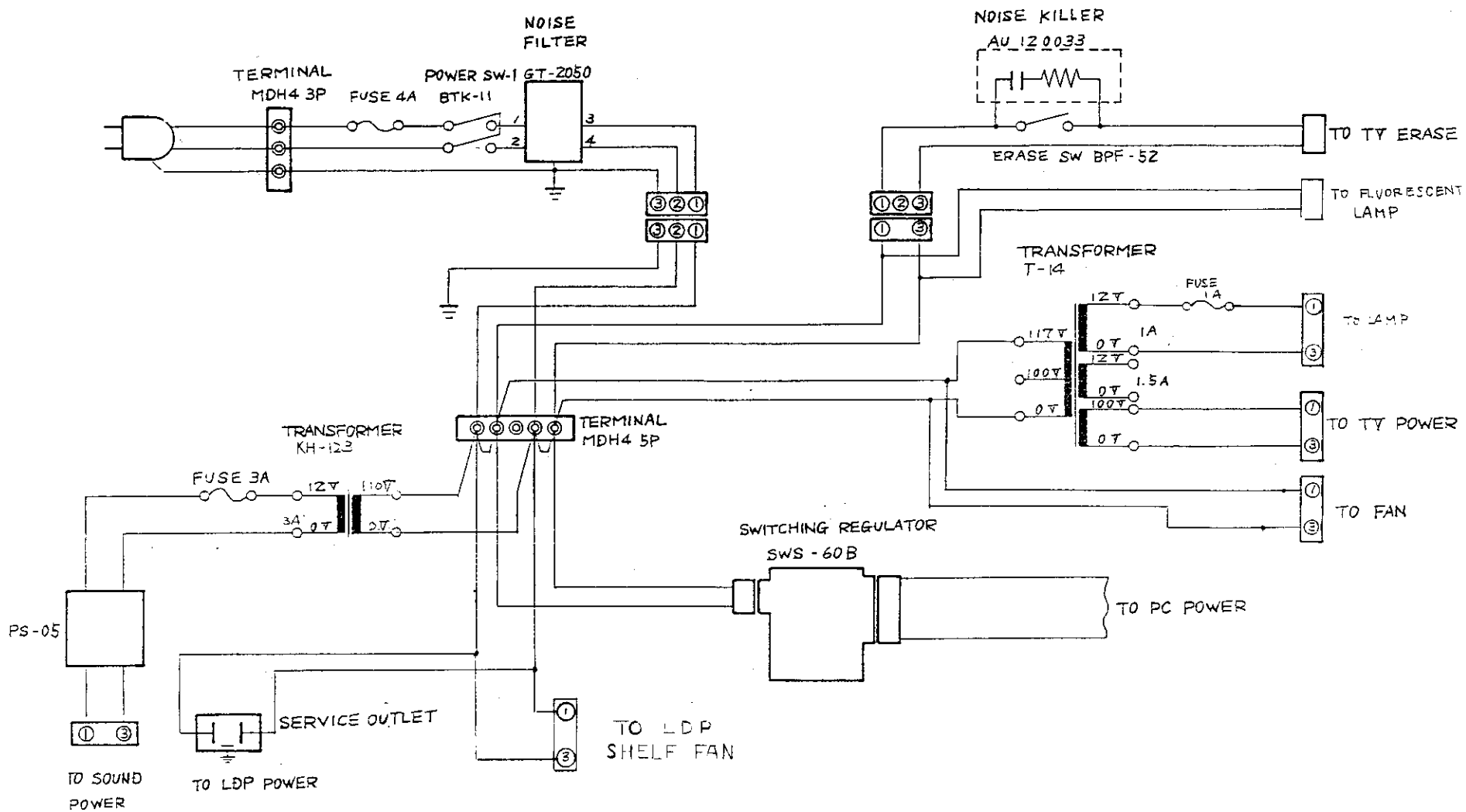

POWER SCHEMATIC DIAGRAM

K-10674

Q101-Q106: 25C1815
 Q107-Q108: 25A2015
 D101-D103: 1S1555
 D402-D405: S5295G

PO01
 SYNC VIDEO-INPUT

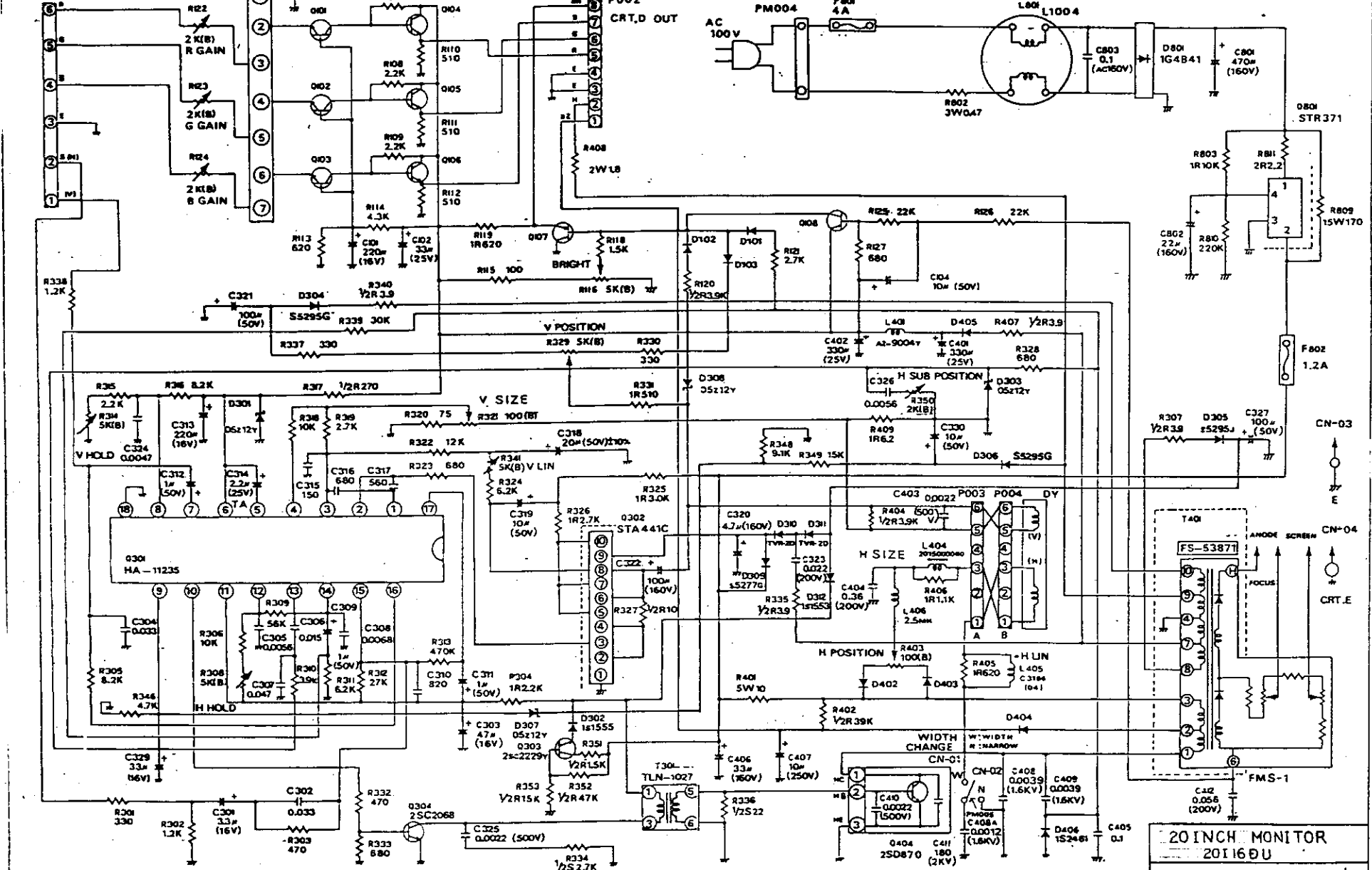

20 INCH MONITOR
 20I16DU
 K-10597

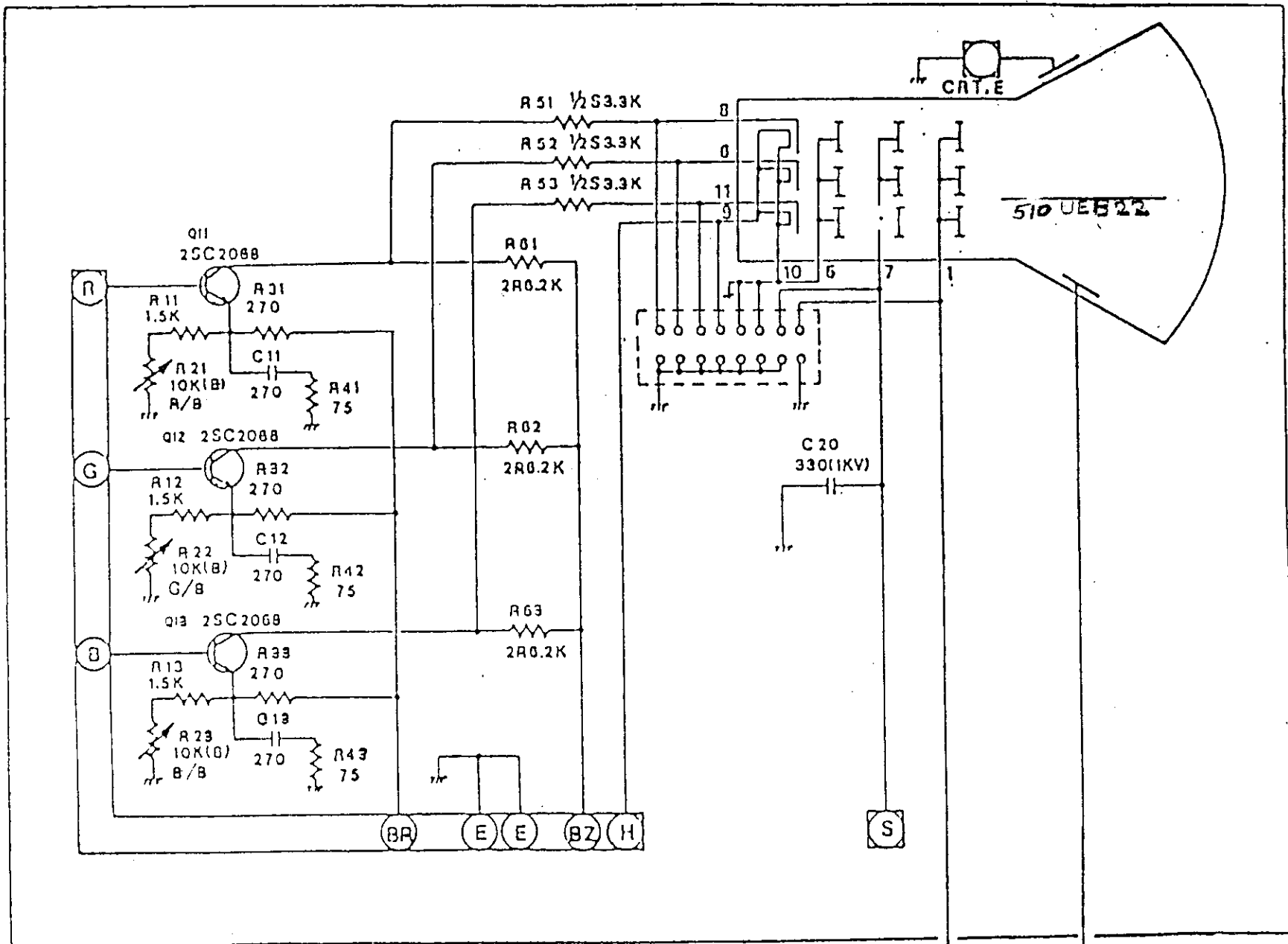

CRT.D W/B (PC1002)

BRIGHT PICTURE TINT
 COLOR CONTRAST
 SUB

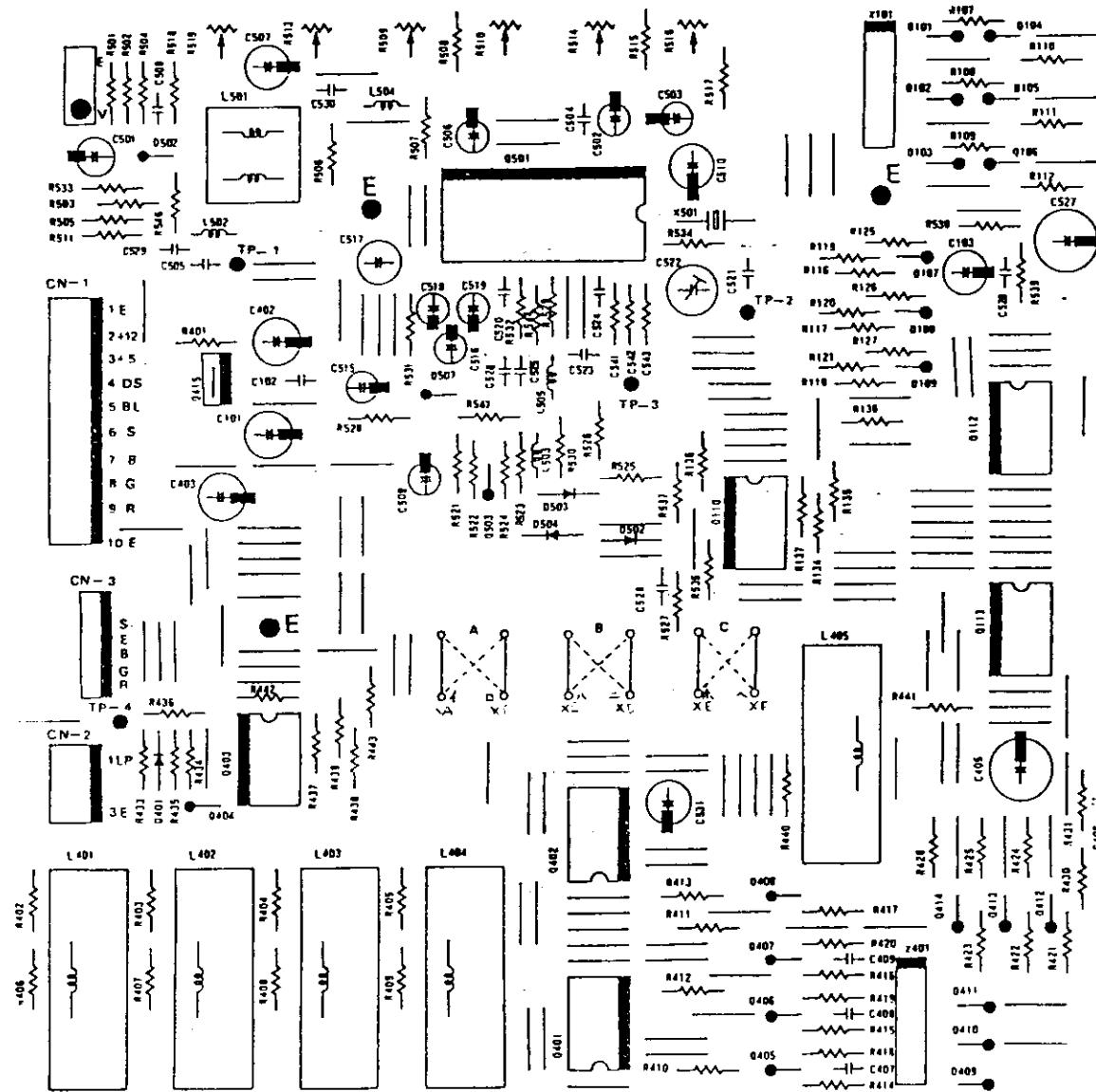

VIDEO CHROMA
 K-10679

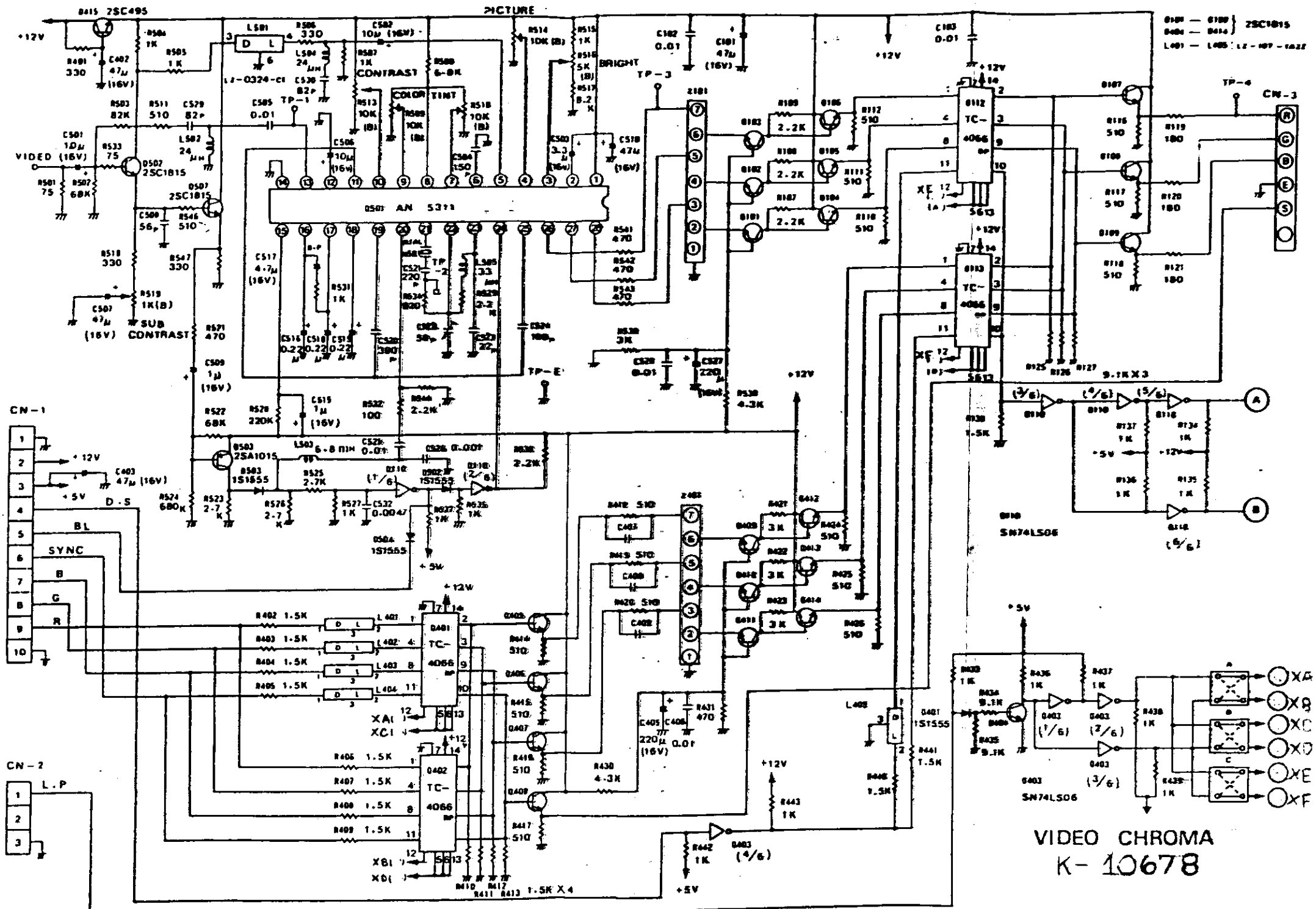

**VIDEO CHROMA
K-10678**

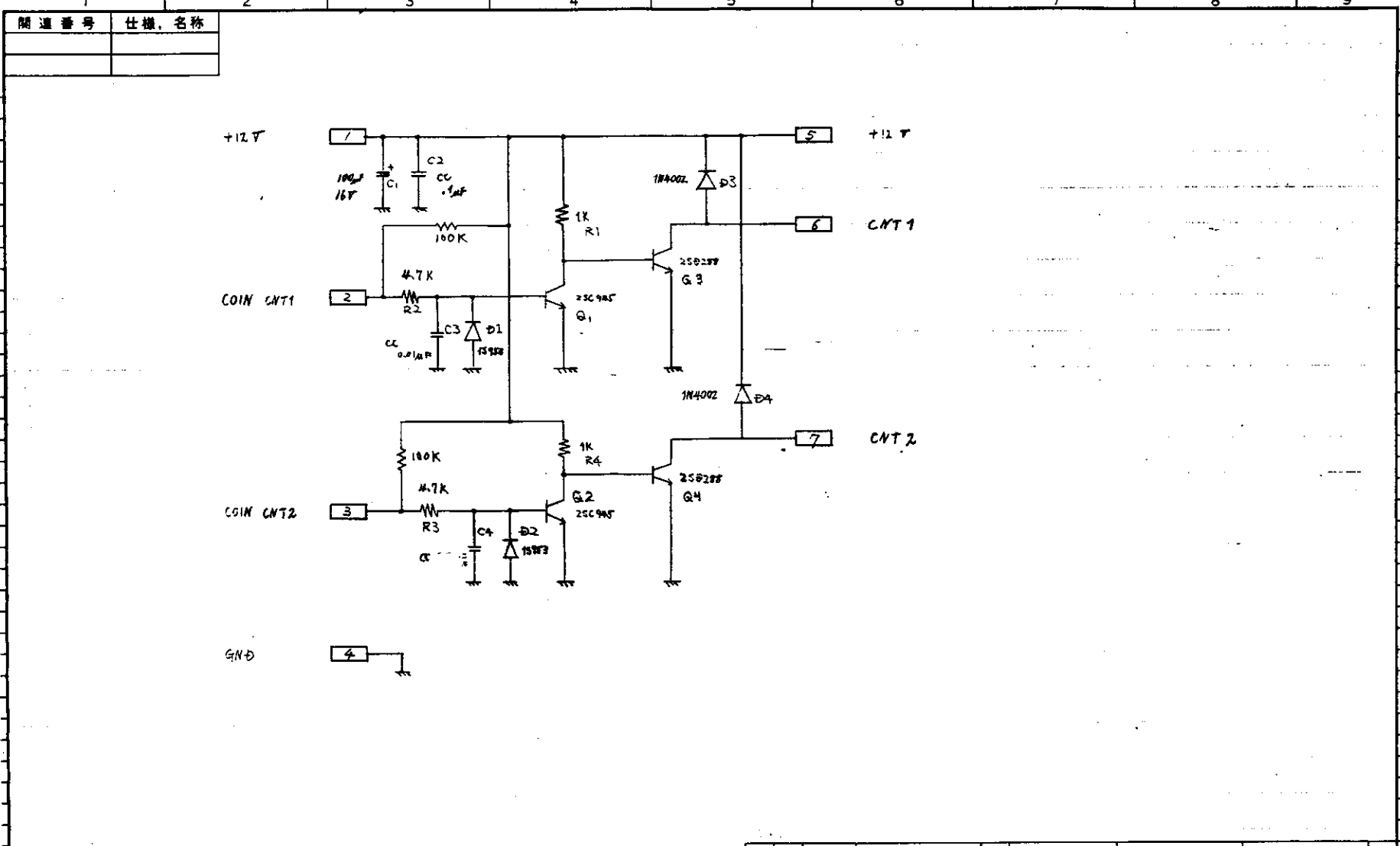

記号	担当	年月日	改訂	個所	符号	部品、図面番号	名称	仕様、材質	備考
記事							名称 COIN COUNTER DRIVER LX-2A コインカウンタ-1/2		
	承認					単位	図番		
	検図					mm			
	57.2.26					尺度	K-10671		1
									1

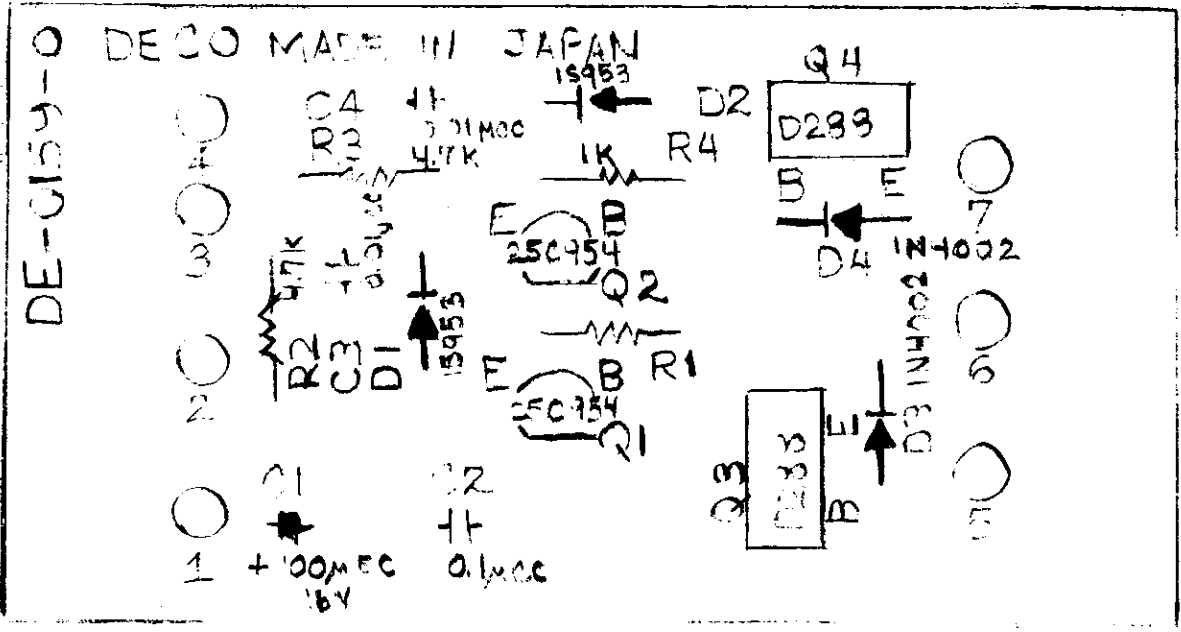

CIF-1

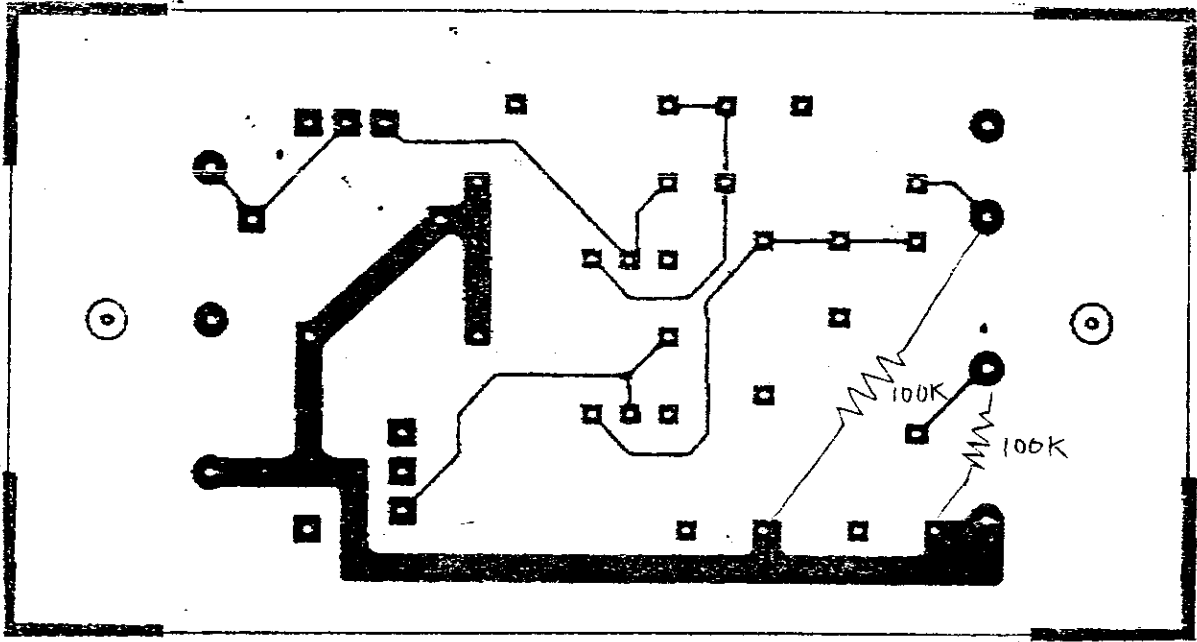

CIF-1

記号	担当	年月日	改訂	箇所	符号	部品, 図面番号	名称	仕様, 材質
材質			処理		公差		名称	COIN COUNTER DRIVER CIF-1 実装図
承認	検図	検図	担当	単位	mm	図面		1
58.8.24		7. KA70	渡辺	R度	/		K-10672	1

関連番号	仕様名称
------	------

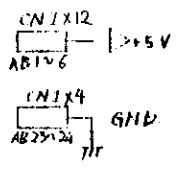
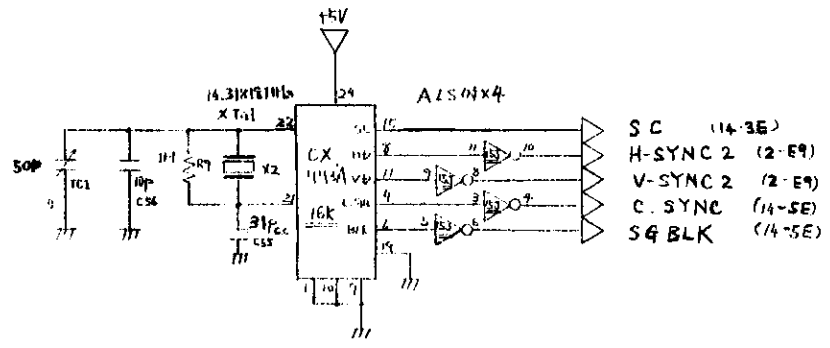
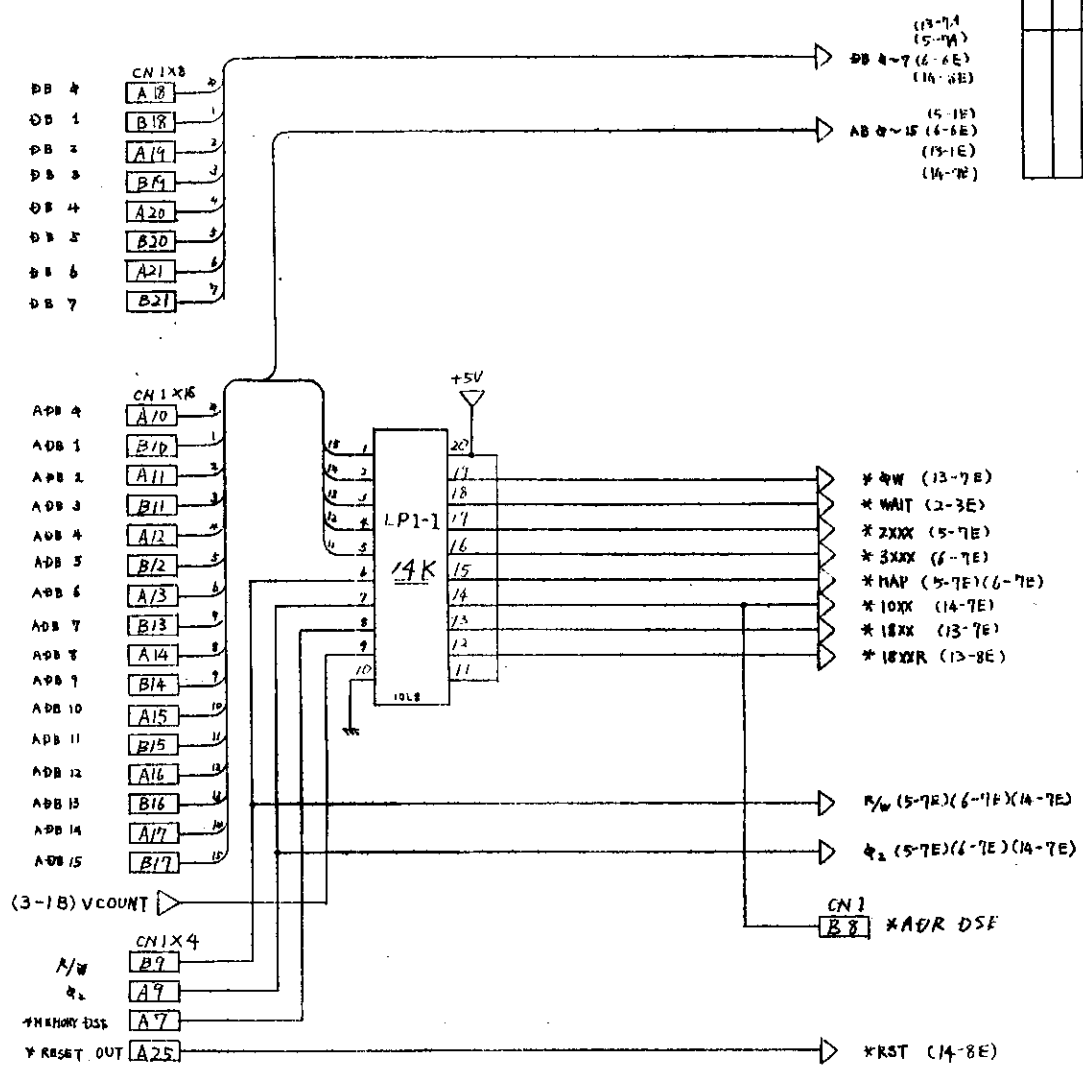

第3角法

起号	担当	年月日	改訂	個所	符号	部品	図面番号	名称	仕様	材質
19/8								DSP CONTROL DECIDE		
検出	検出									
承認	承認									
単位	mm									
図番										
名称: LX-2A TDC-1 仕様: DSP CONTROL DECIDE 図番: K-10667										

LX-2A TDC-1
DSP CONTROL DEC
K-10667

DEHI 電子工業株式会社

開運番号 仕様, 名称

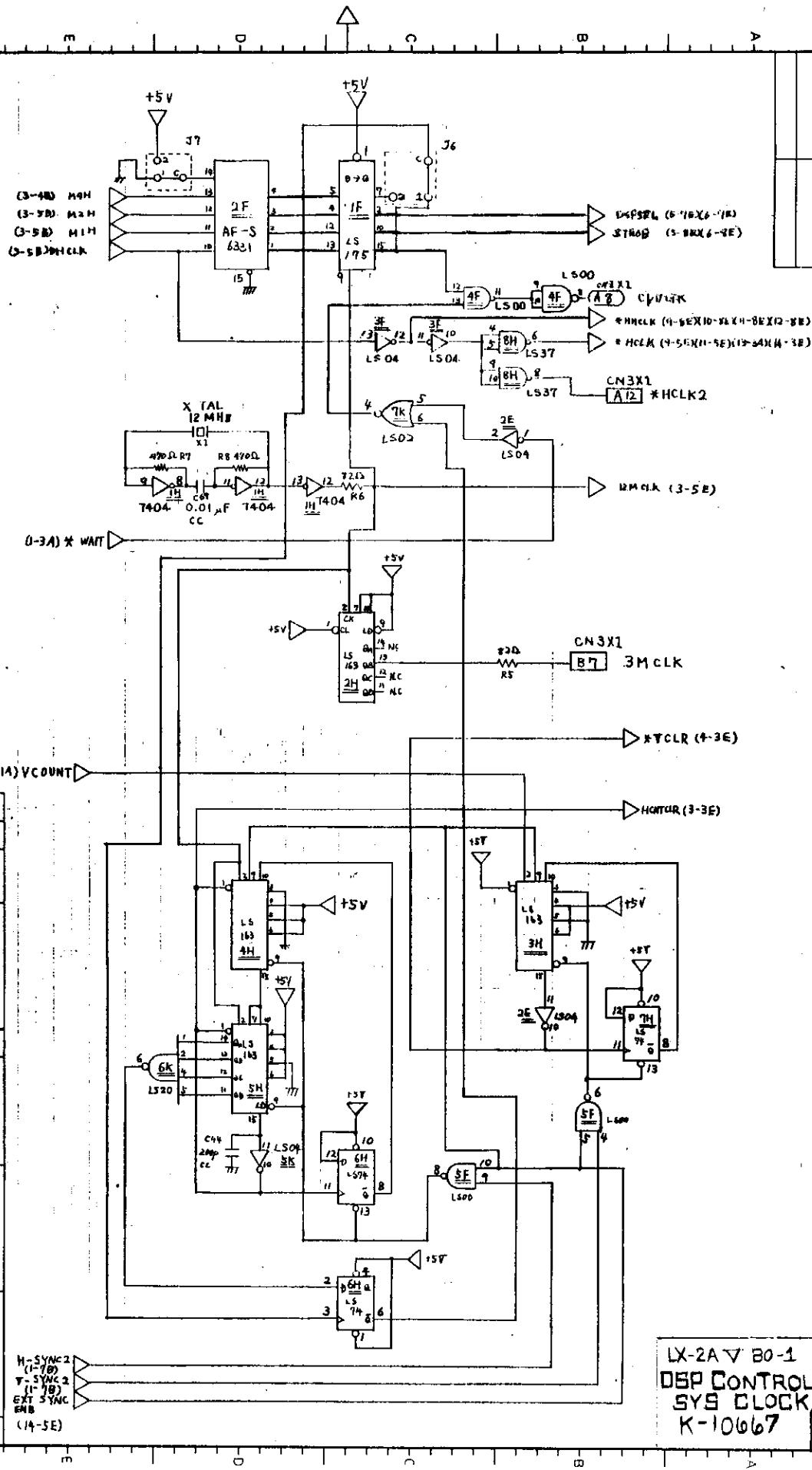

第 3 角法

記号	年月日	改訂個所	符号	部品、図面番号	名称	仕様、材質	数量
材料		処理			DSP CONTROL SYSTEM CLOCK		
承認		検印			名称	仕様、材質	数量
2/1/76		2/11/76			LX-2A V B0-1		
58.9.26		58.8.22			DSP CONTROL SYSTEM CLOCK		
単位	mm	公差			名称	仕様、材質	数量
					K-10667		
図番							

三菱電機株式会社

LX-2A V B0-1
DSP CONTROL
SYS CLOCK
K-10667

製造番号	仕様、名称

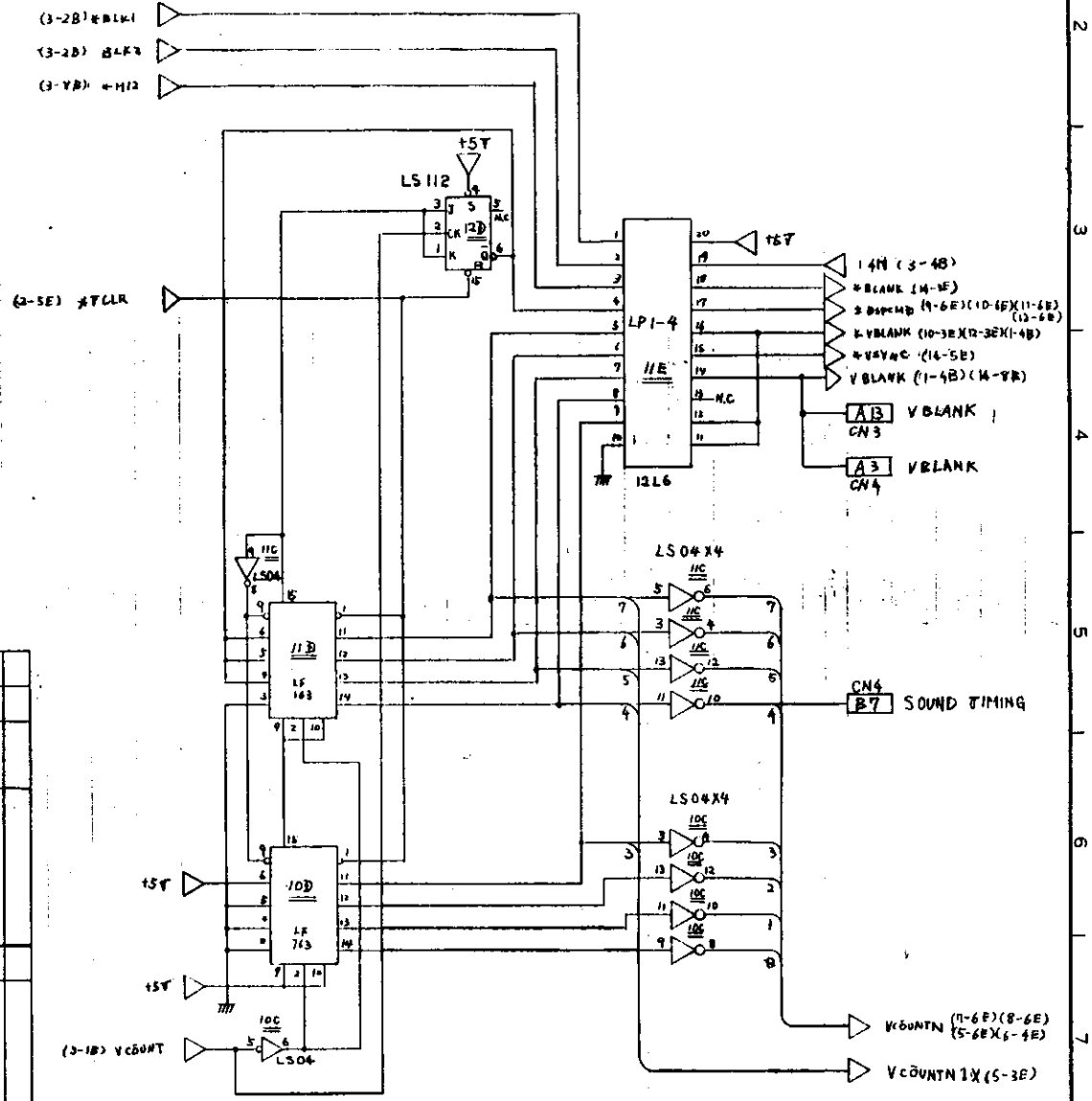

記号		年月日		改訂箇所		符号		製品、図面番号		名称、仕様、材質	
材質		処理		公差		公差		名称		仕様、材質	
承認	検出	検出	検出	単位	mm	公差	公差	名称	仕様、材質	数量	単位
承認	検出	検出	検出	単位	mm	公差	公差	名称	仕様、材質	数量	単位
承認	検出	検出	検出	単位	mm	公差	公差	名称	仕様、材質	数量	単位
承認	検出	検出	検出	単位	mm	公差	公差	名称	仕様、材質	数量	単位

第3角法

三菱電機株式会社

LX-2A V DO-1
 DSP CONTROL V-COUNTER
 K-10667

第3頁

承認 5/15/82 5/21/82	検印 TAKA 5/21/82	検印 5/21/82	検印 5/21/82	検印 5/21/82	検印 5/21/82
材料	年月日	改訂箇所	符号	部品、図面番号	名
		処理			称
					仕様、材質
					名
					LPX-2A TPO-1
					DSP CONTROL B MAPSAH
					図番
					K-10667
					6
					1/4

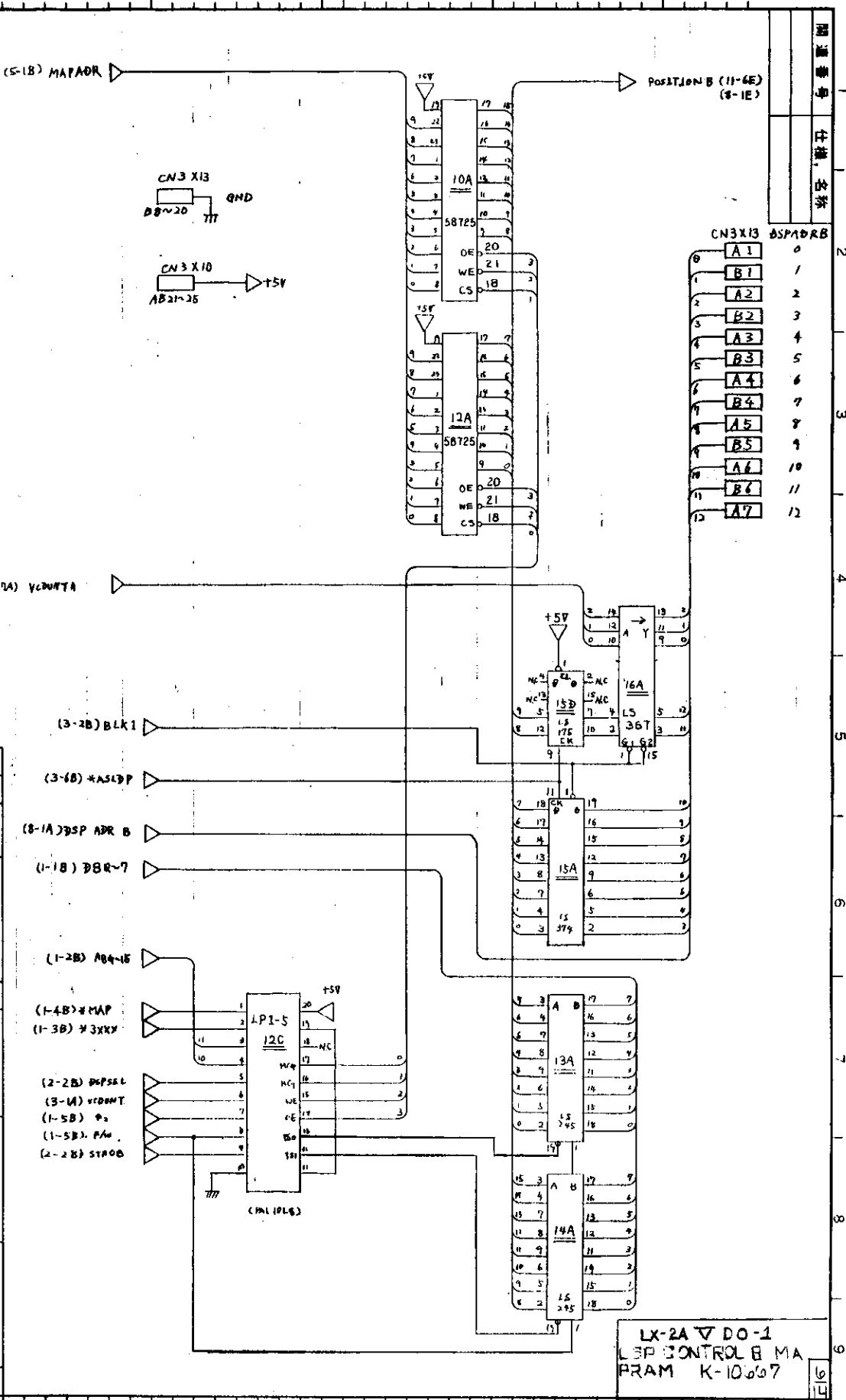

LX-2A V DO-1
DSP CONTROL B MA
PRAM K-10667

第3角法

材料	日期	年月日	改訂欄	所	符号	部品、図面番号	名	仕様、材質	7
承認	作成		確認				LX-2A	TBD-1	14
承認	作成		確認				DSP CONTROL A MIXCMT		
承認	作成		確認				K-10667		
承認	作成		確認						

富士通株式会社

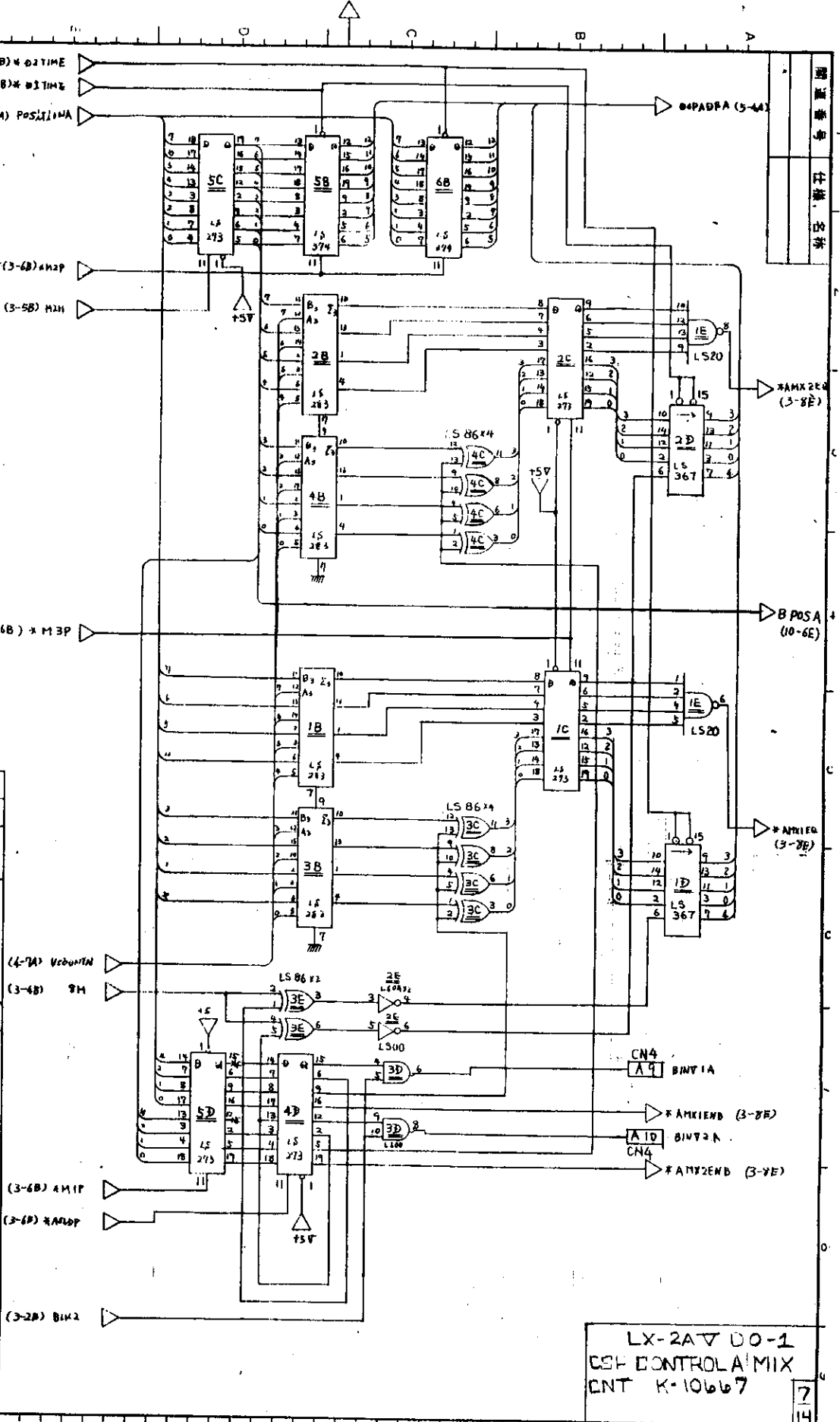

LX-2A 00-1
 DSP CONTROL A MIX
 CNT K-10667
 7/14

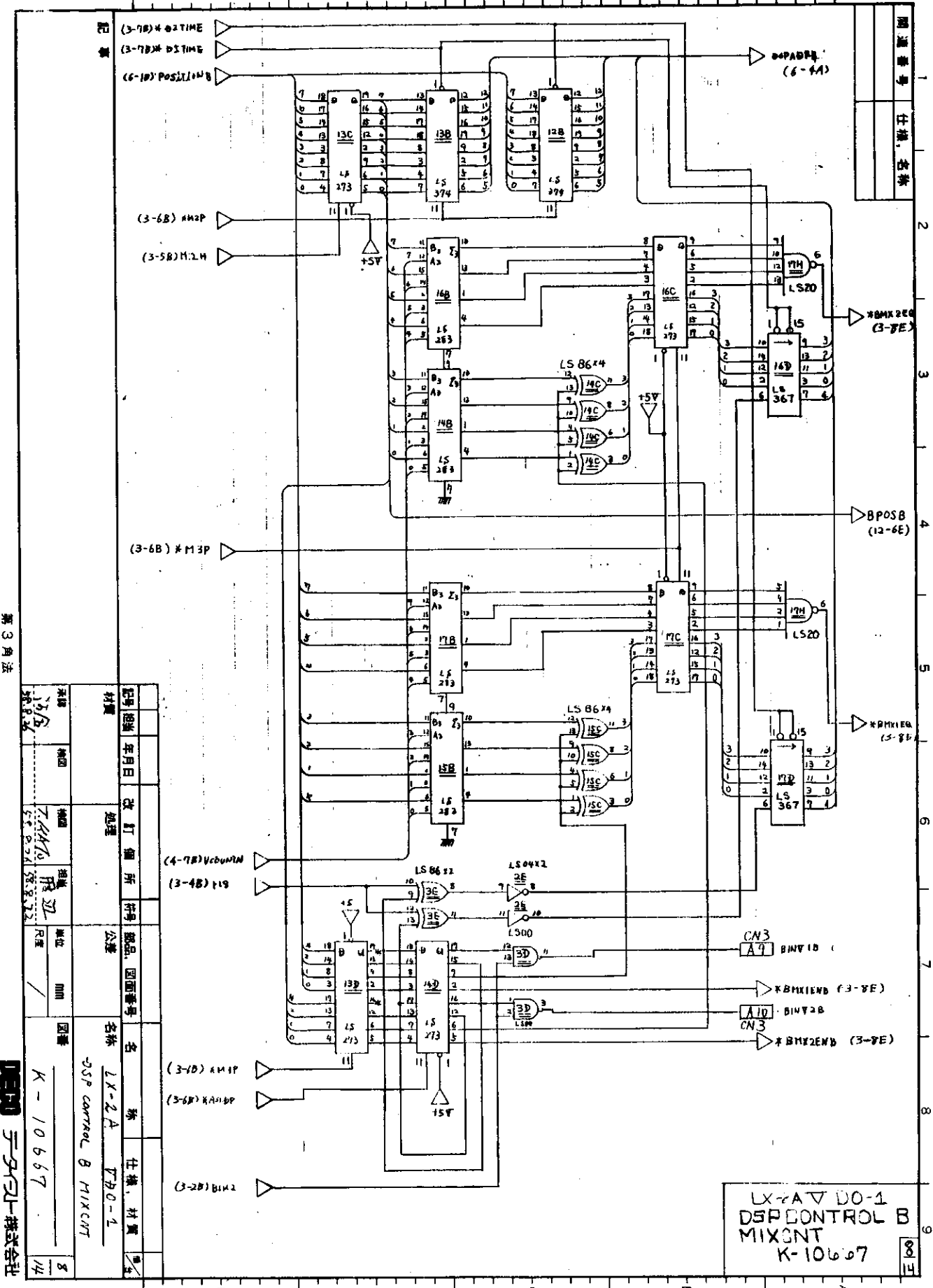

回路番号	1
仕様, 名称	2

第3角法

材料	記号	数量	年月日	改訂	場所	品番	図面番号	名称	仕様, 材質
1/10								LX-2A	770-1
								DSP CONTROL B MIXCNT	
1/10								K-10667	

NEC 電子工業株式会社

LX-2A V D0-1
 DSP CONTROL B
 MIXCNT
 K-10667

1/14

回路番号	仕様、名称

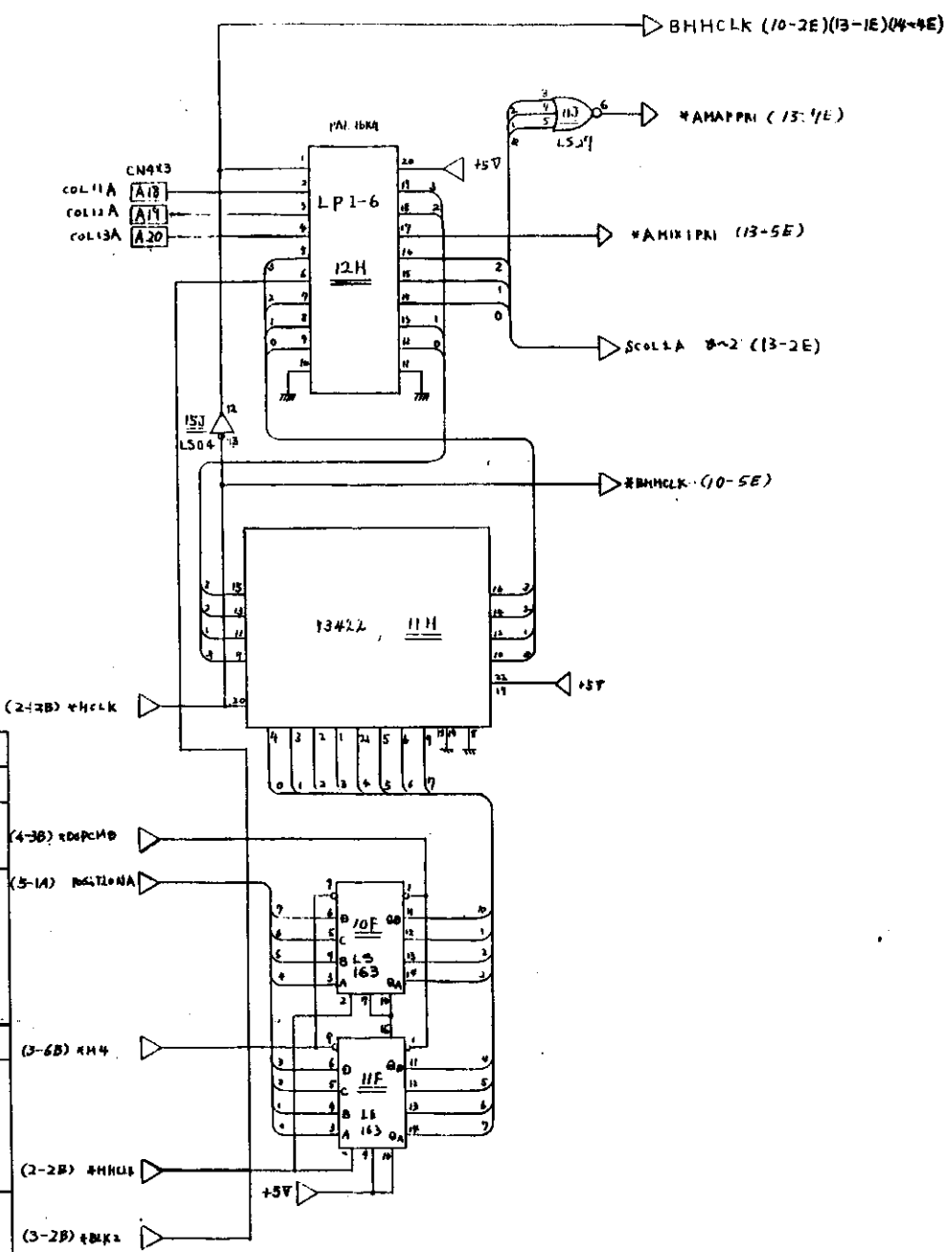

記事

第3角法

記号	担当	年月日	改訂場所	行号	部品、図面番号	名称	仕様、材質	数量
材質			処理		公差	名称	仕様、材質	数量
10F			10F			LX-2A	T70-1	9
13422			13422			USP CONTROL LINE BUFFER 1		1
10F			10F			K-10667		1/4

LX-2A V DO-1
USP CONTROL A
LINE BUFFER 1
K-10667

富士通株式会社

圖面番号	仕様, 名称

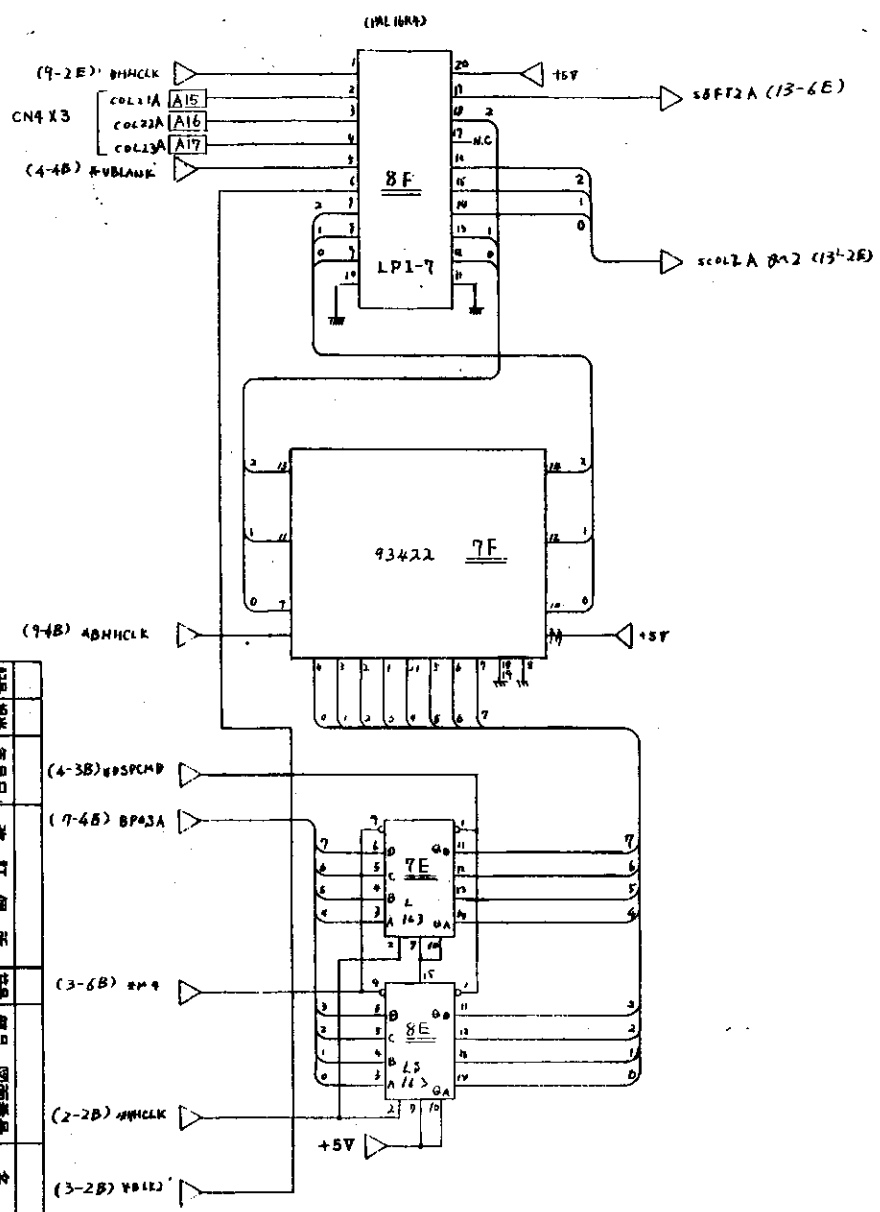

第3角法

承認 8F	検閲	承認 7E	検閲 7F	承認 7E	検閲 7F	承認 7E	検閲 7F
年月日	改訂箇所	年月日	改訂箇所	年月日	改訂箇所	年月日	改訂箇所
材料	処理	材料	処理	材料	処理	材料	処理
記号	部品, 図面番号	記号	部品, 図面番号	記号	部品, 図面番号	記号	部品, 図面番号
名称	名称	名称	名称	名称	名称	名称	名称
LX-2A	TPO-4	LX-2A	TPO-4	LX-2A	TPO-4	LX-2A	TPO-4
DSP CONTROL A LINE BUFFER 2		DSP CONTROL A LINE BUFFER 2		DSP CONTROL A LINE BUFFER 2		DSP CONTROL A LINE BUFFER 2	
図番	図番	図番	図番	図番	図番	図番	図番
K-10667	K-10667	K-10667	K-10667	K-10667	K-10667	K-10667	K-10667
10	10	10	10	10	10	10	10
1/4	1/4	1/4	1/4	1/4	1/4	1/4	1/4

LX-2AV DO-1
DSP CONTROL A
LINE BUFFER
K-10667

子タロ一株式会社

圖番 100-10667-1	仕様 名称
-------------------	----------

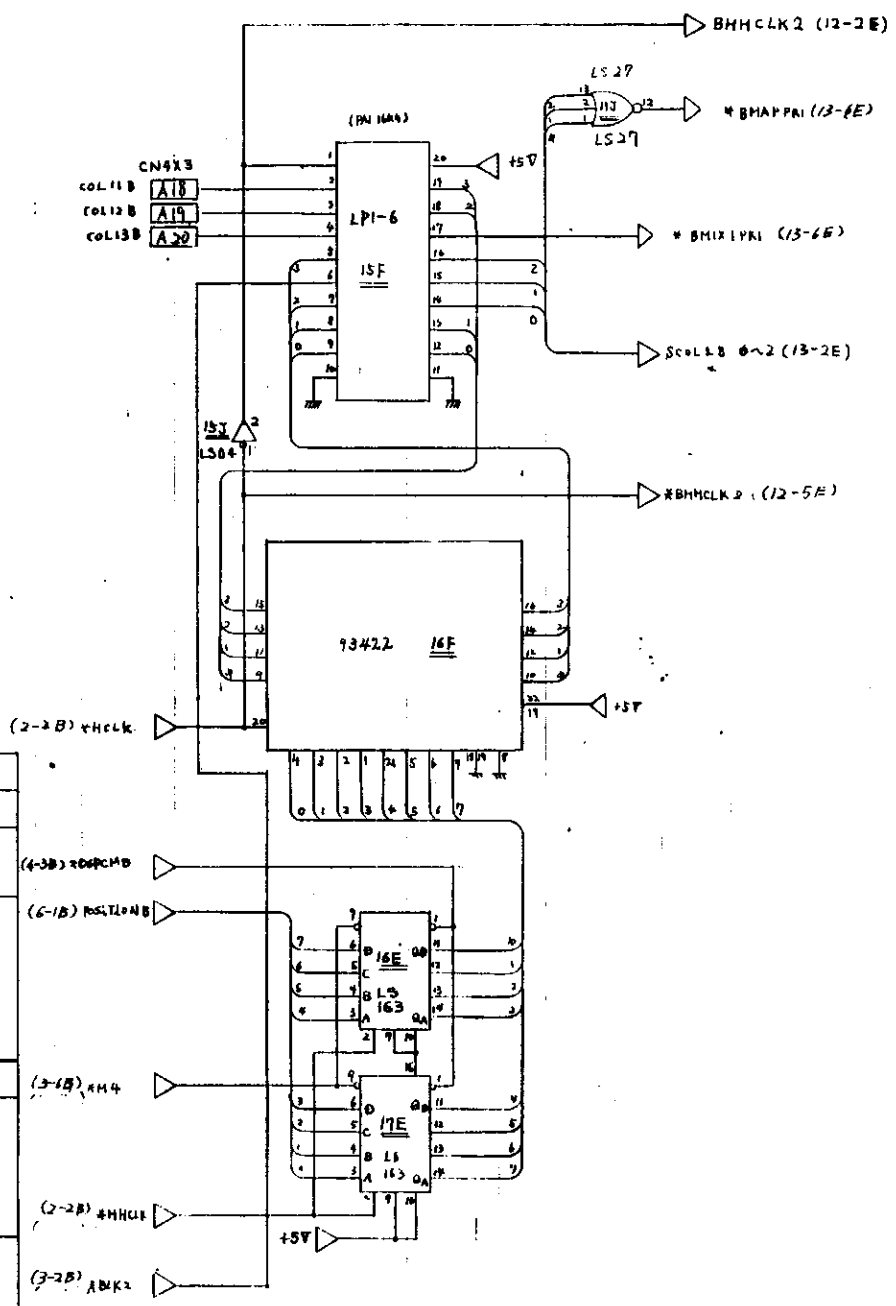

記号

記号	担当者	年月日	改訂箇所	符号	部品、図面番号	名称	仕様、材質	図番
						DSP CONTROL B LINE BUFFER-1	7900-1	
承認	検印	検印	検印	検印	検印			
100-10667-1								

第3角法

100-10667-1 子資料株式会社

LX-2A7DO-1
DSP CONTROL B
LINE BUFFER
K-10667

1	機種, 名称
2	
3	
4	
5	
6	
7	
8	
9	
10	

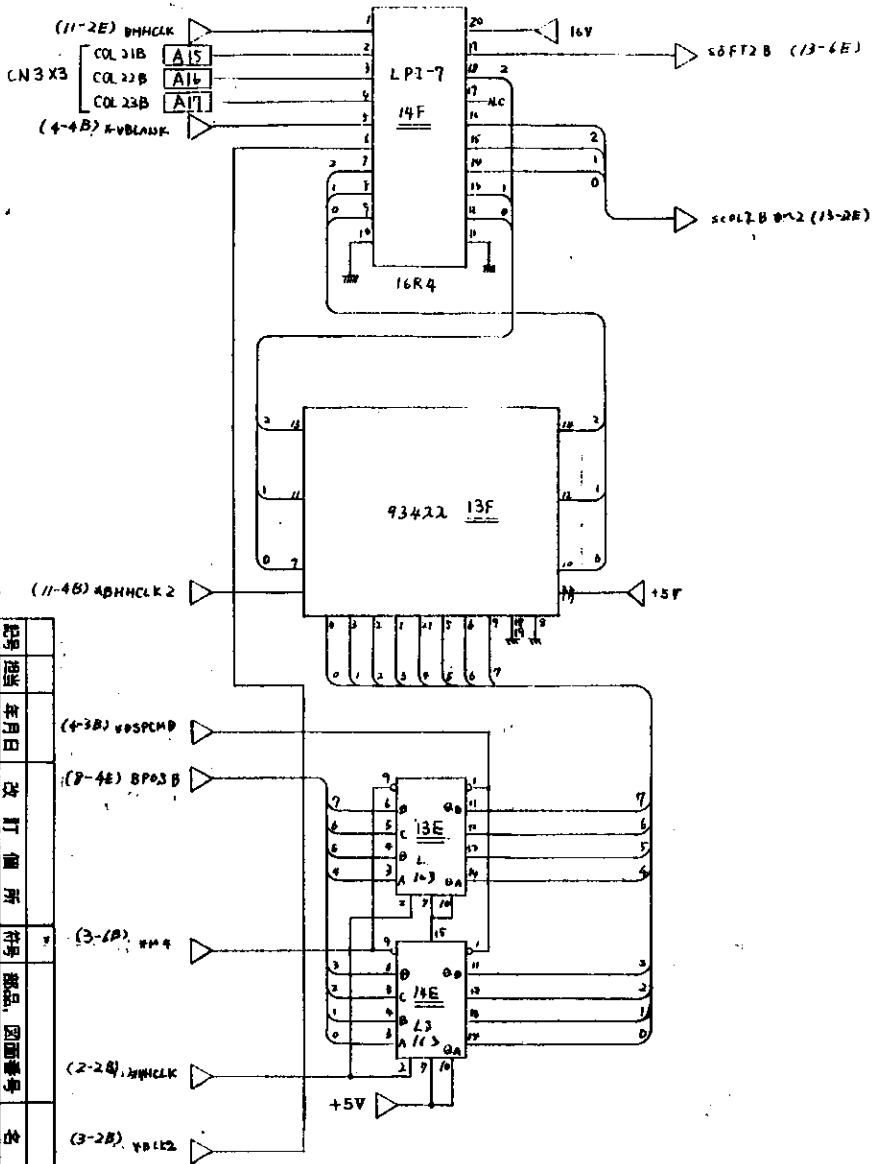

記 載

第 3 角 法

材料	記号	担当	年月日	改訂	價所	符号	部品	図面	番号	名	称	仕様	材質	量
材料										名称	仕様, 材質			
材料										LX-2A	V90-1			
材料										DSP CONTROL B LINE BUFFER 2				
材料										K-10667				1/2
材料														1/4

LX-2A▽D0-1
 DSP CONTROL B
 LINE BUFFER 2
 K-10667

富士通株式会社

圖樣番號	仕様、名称
------	-------

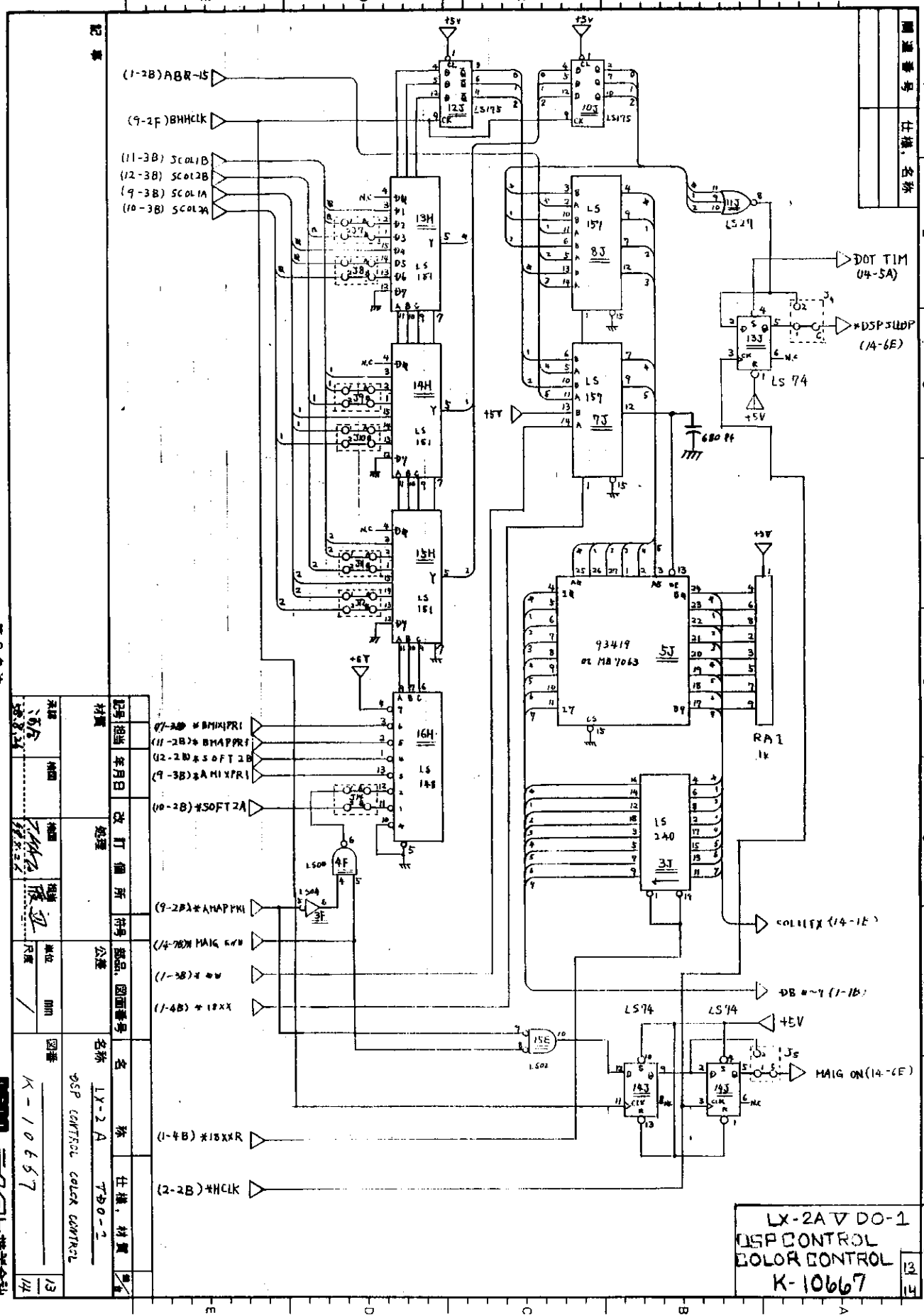

第3角法

1991 富士通株式会社

材料	記号	担当者	年月日	改訂	備考	部品、図面番號	名	仕様、材質
LS157	(7-2B) *BHMIXPRI					LS	LX-2A	T90-1
LS157	(11-2B) *BMAPPRI					LS	DSP CONTROL COLOR CONTROL	
LS157	(12-2B) *SOFT2B					LS		
LS157	(9-3B) *AMIXPRI					LS		
LS157	(10-2B) *SOFT2A					LS		
LS74	(9-2B) *AMAPPRI					LS		
LS155	(14-7B) HAIG SW					LS		
LS74	(1-3B) *SW					LS		
LS74	(1-4B) *12XX					LS		
LS74	(1-4B) *18XXR					LS		
LS74	(2-2B) *HCLK					LS		

LX-2A VDO-1
DSP CONTROL
COLOR CONTROL
K-10667

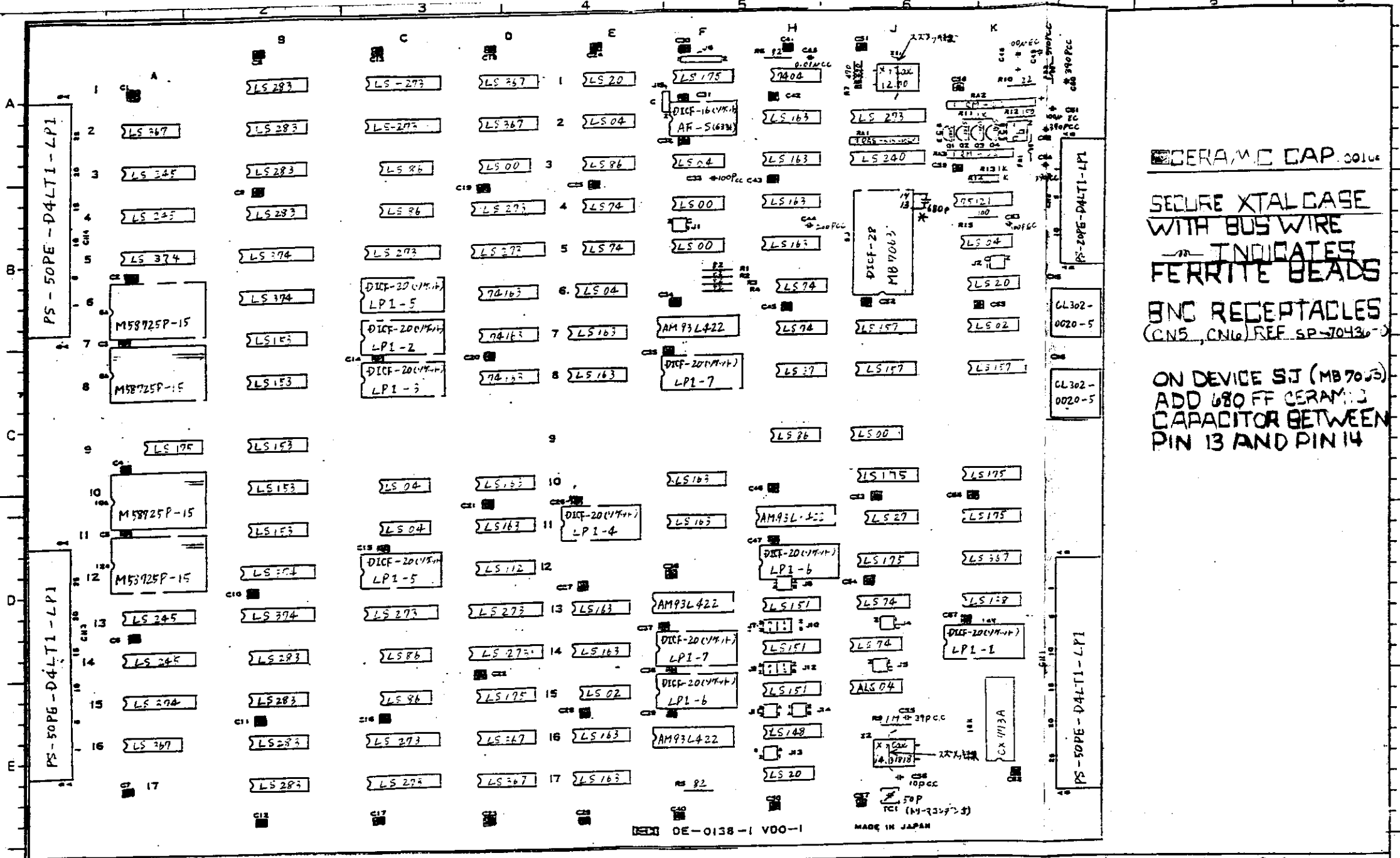

CERAMIC CAP

SECURE XTAL CASE
WITH BUS WIRE
INDICATES
FERRITE BEADS

BNC RECEPTACLES
(CN5, CN6) REF SP-7043

ON DEVICE SJ (MB7005)
ADD 680 PF CERAMIC
CAPACITOR BETWEEN
PIN 13 AND PIN 14

記事				材質		処理		公差		名称	
										LX-2A VDO-1実装図	
承認		検閲		検閲		検査		単位		図番	
SP. R. 2		TKA		渡辺		単位		/		K-10669	
										1/1	

第3角法

材料	記号	担当者	年月日	改訂箇所	符号	部品、図面番号	名称	仕様、材質
承認 KATO	52.8.26	承認 KATO		承認 KATO			名称 MAIN CPU	仕様、材質 LX-24 VDC-2
承認 KATO	52.8.26	承認 KATO		承認 KATO			名称 MAIN CPU	仕様、材質 LX-24 VDC-2
承認 KATO	52.8.26	承認 KATO		承認 KATO			名称 MAIN CPU	仕様、材質 LX-24 VDC-2
承認 KATO	52.8.26	承認 KATO		承認 KATO			名称 MAIN CPU	仕様、材質 LX-24 VDC-2

DEFO 子会社

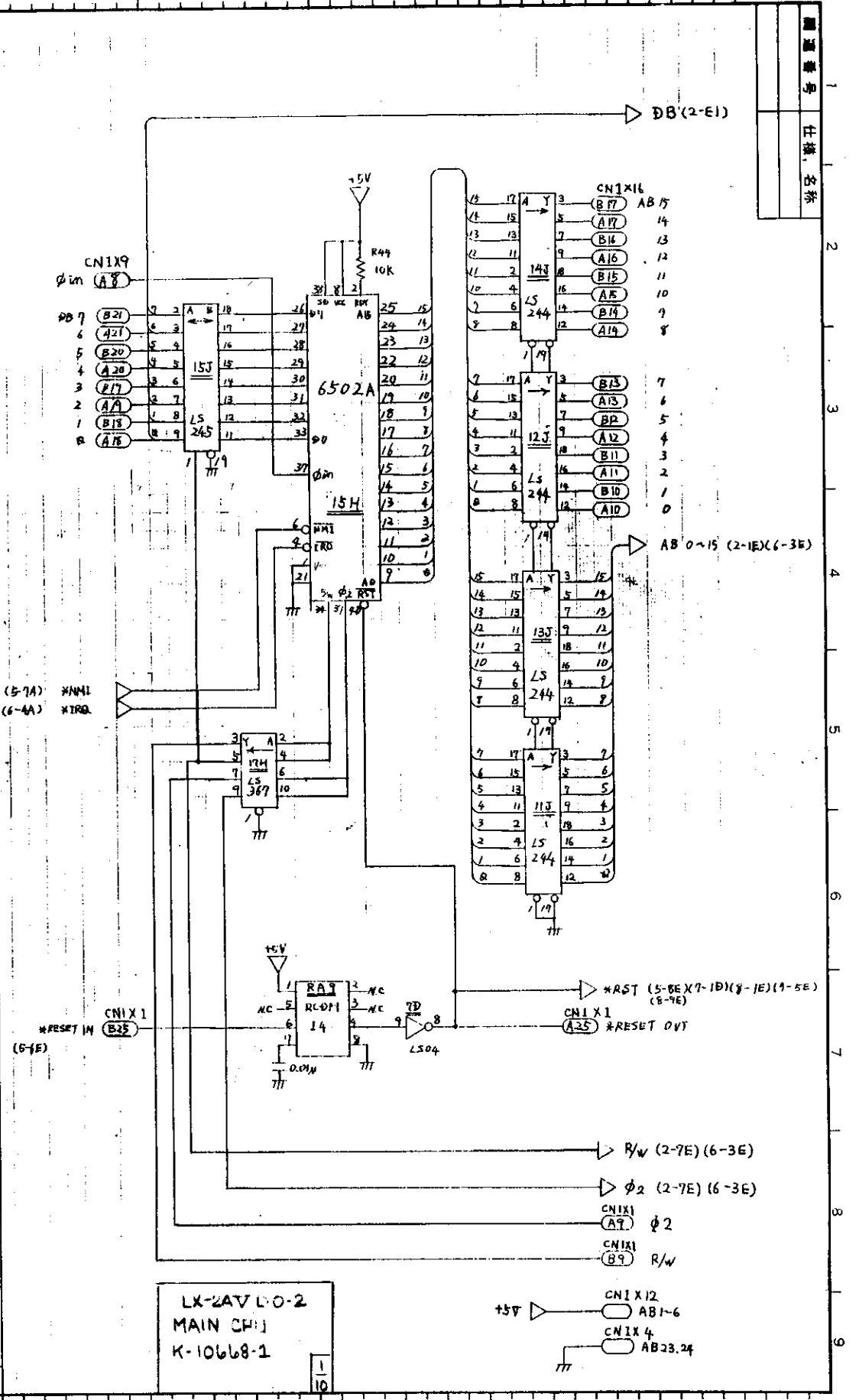

LX-24V D.O-2
MAIN CPU
K-10668-1

1	圖書番号	仕様、名称
2		
3		
4		
5		
6		
7		
8		
9		

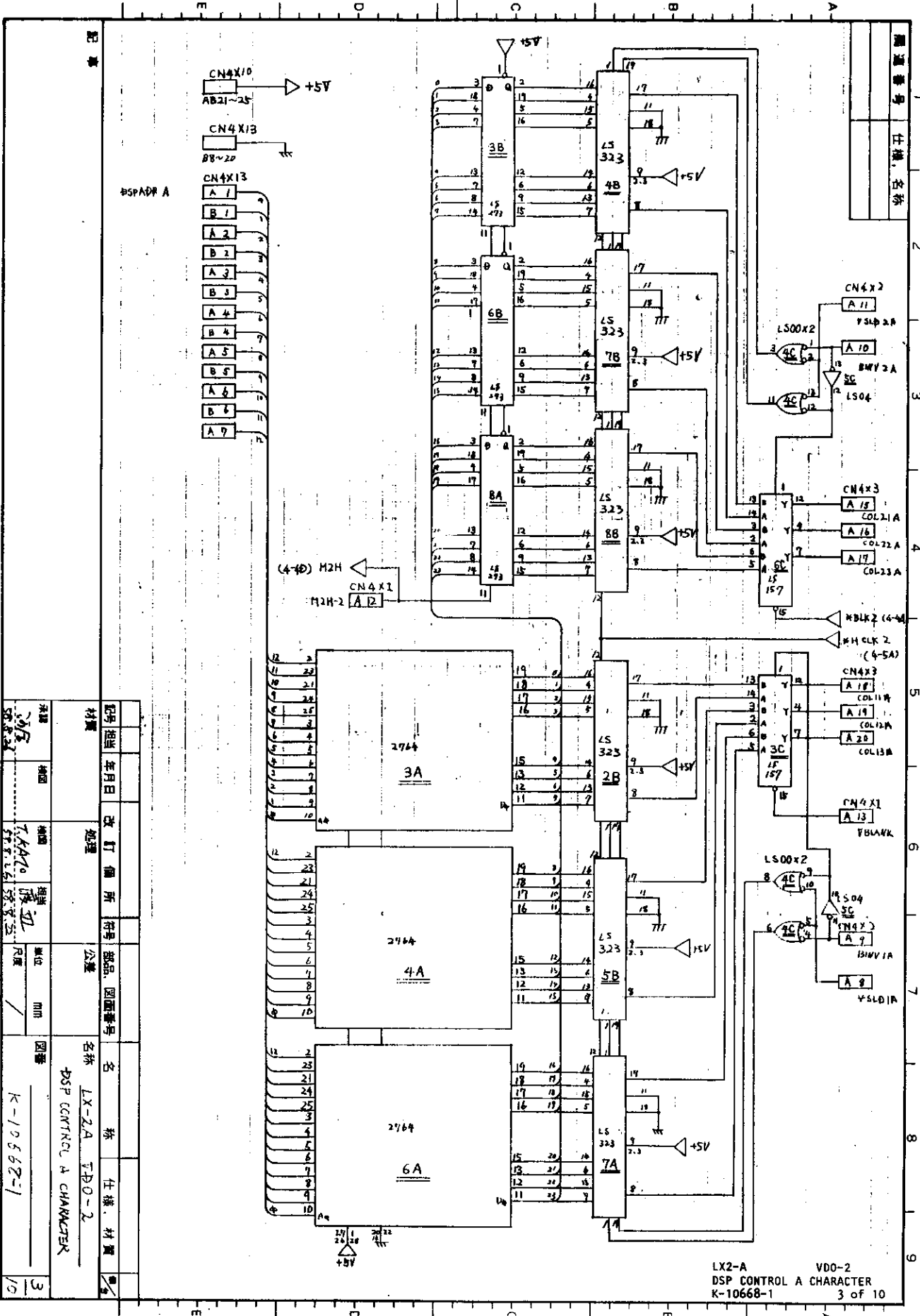

第 3 角法

NEC 子会社

記号	招請	年月日	改訂	備所	符号	部品	図面番号	名	称	仕様	材質	量
10/20	10/20							LX-2A	IBD-2		DSP CONTROL A CHARACTER	3
10/20	10/20							K-10668-1				10

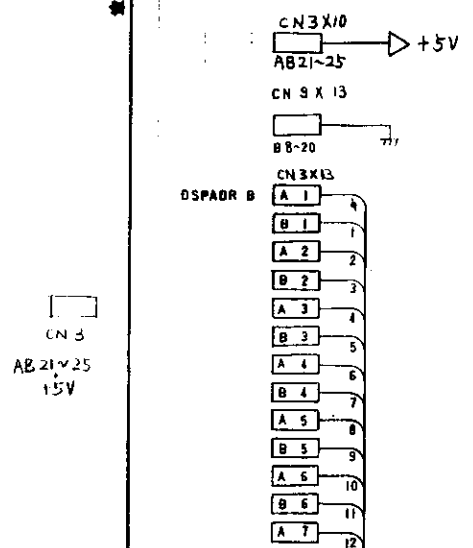
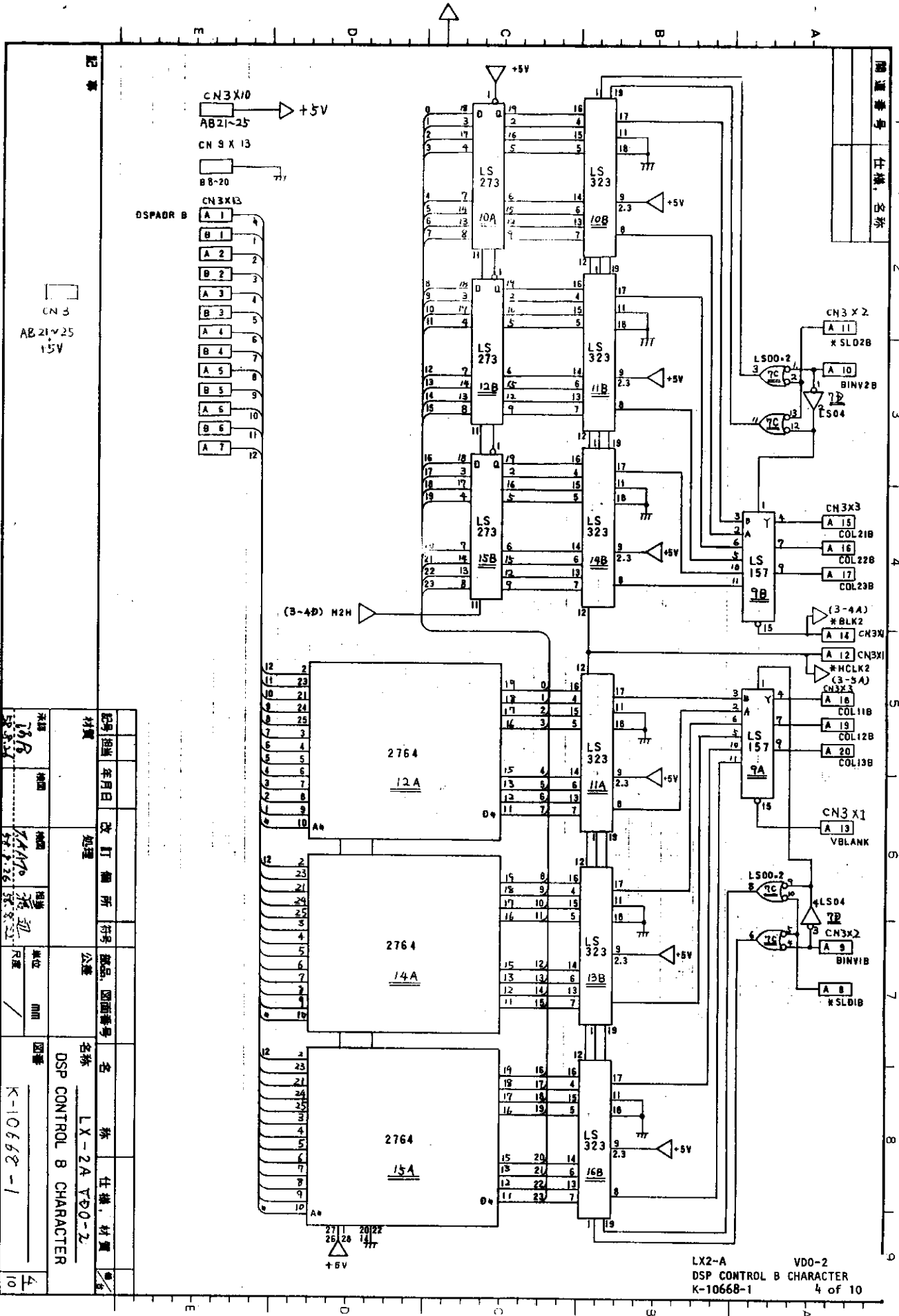

第3角法

材料	部品	年	日	改	訂	編	所	符	号	部	品	圖	面	番	号	名	称	任	務	材	質	第
																LX-2A	VDO-2					4
																DSP CONTROL B CHARACTER						5
																K-10668-1						10

DEPO 子子子子子子子子子子

2
3
4
5
6
7
8
9

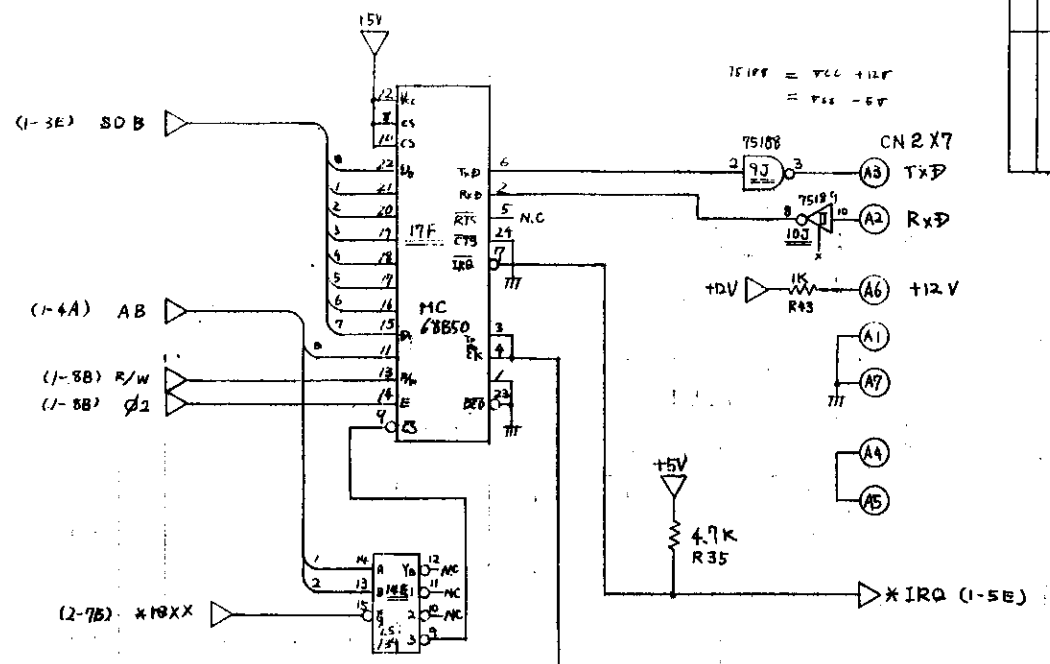

$$75108 = VCC + 12V \\ = P_{44} - 6F$$

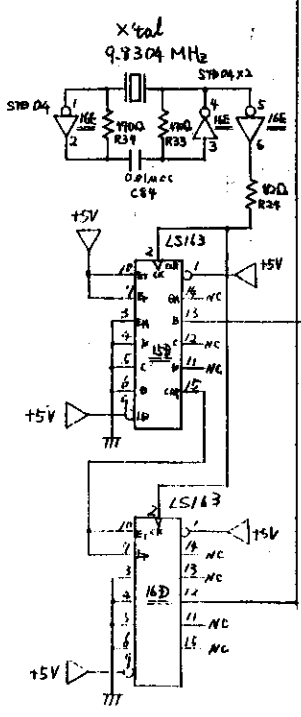

2.5 MCLK (7-2E)

記号

品番	年月日	改訂箇所	符号	部品、図面番号	名称	仕様、材質
材料		処理		公差	LX-2A	VDO-2
承認				単位	RS-232C	4/F
検出				加印	K-10668-1	1/10

第3号法

富士通株式会社

製造番号	
仕組名称	

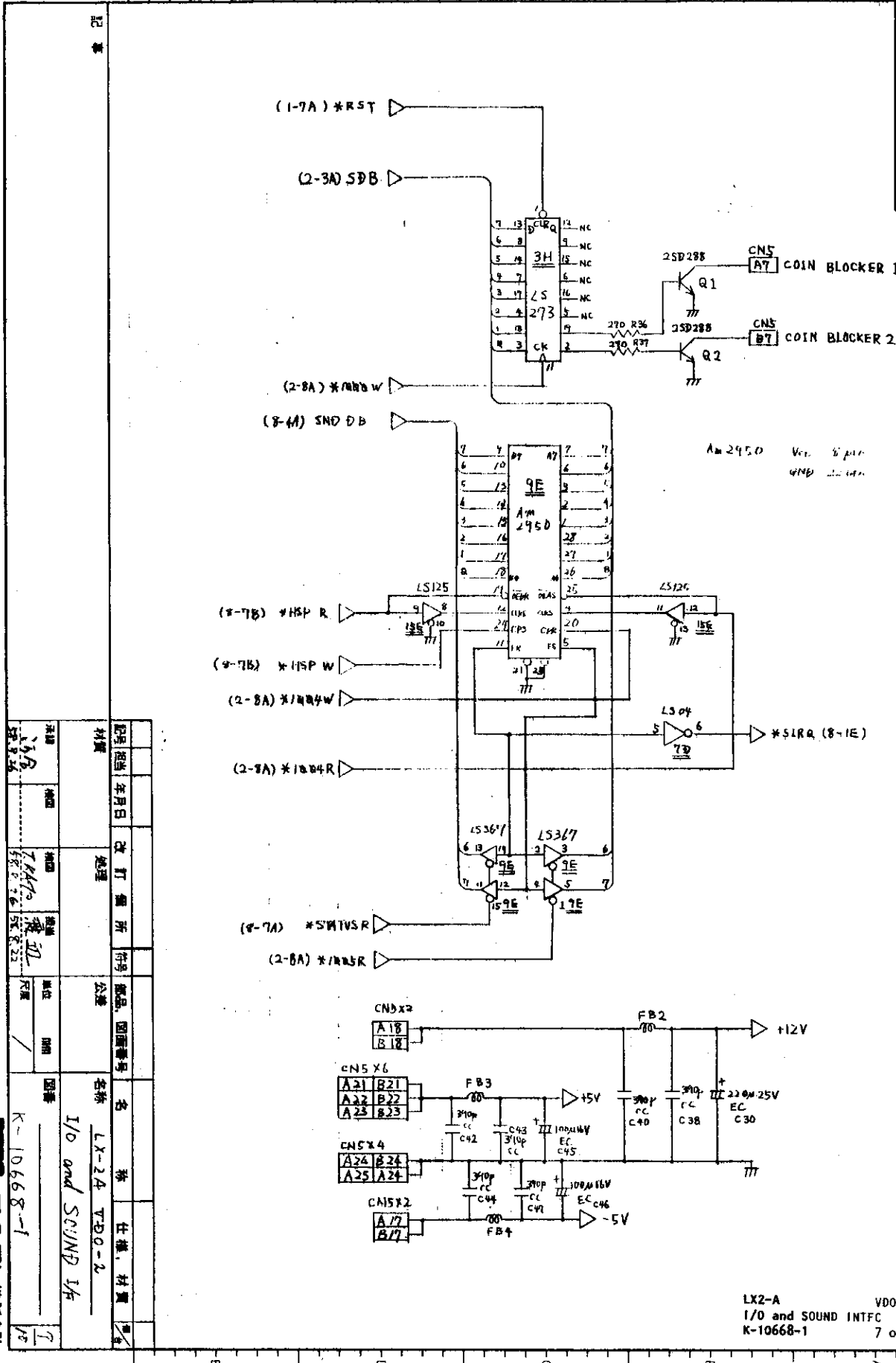

第3巻法

記号	記号	記号	記号	記号	記号	記号	記号	記号	記号
年	日	月	日	年	日	月	日	年	日
材料	材料	材料	材料	材料	材料	材料	材料	材料	材料
改訂	編	所	符号	部品	図面	番号	名	称	仕
名	称	仕	組	材	質	名	称	仕	組
I/O and SOUND I/F									
K-10668-1									

富士通株式会社

関連番号 仕様, 名称

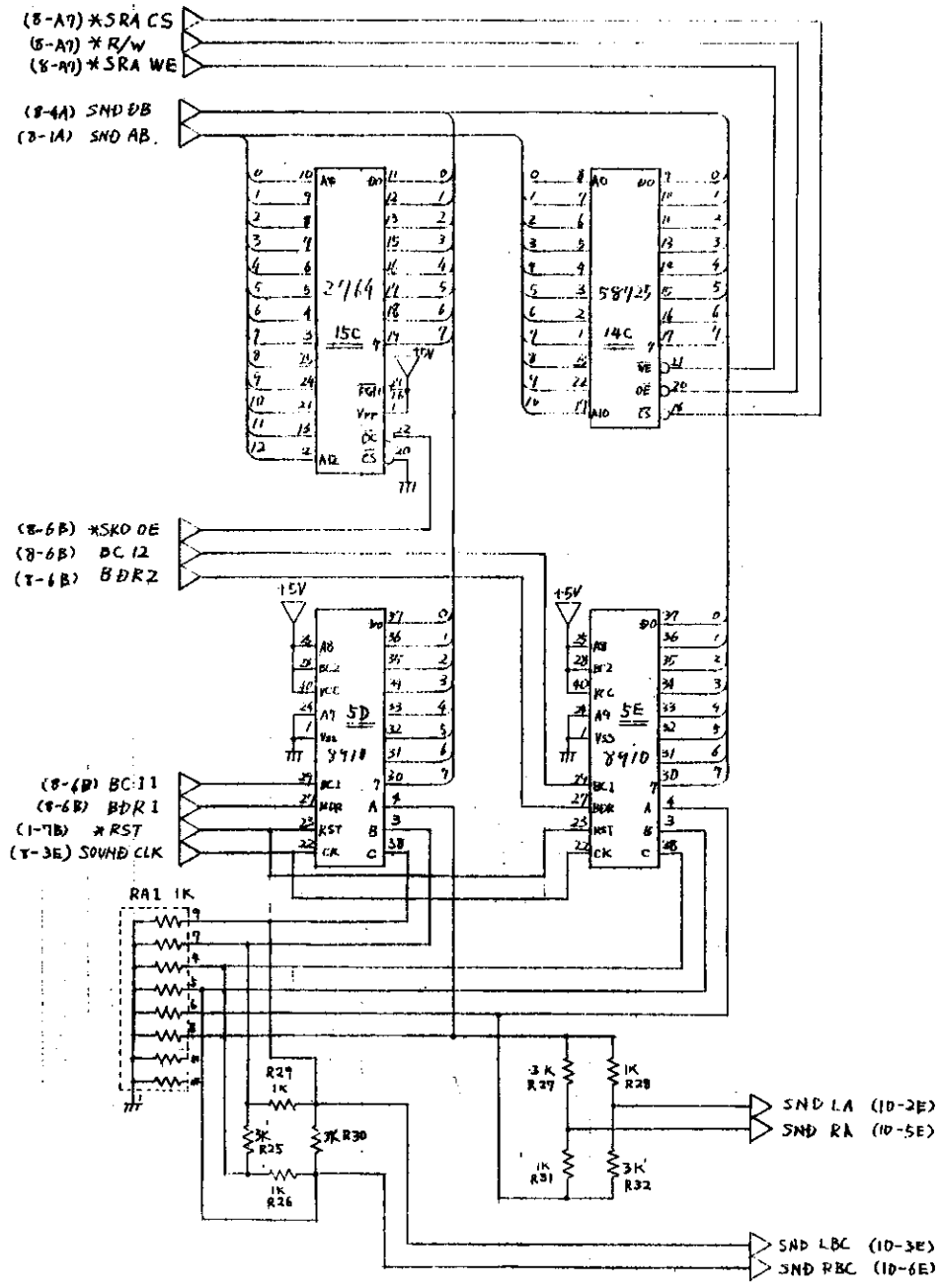

(8-A7) *SRA CS
(8-A7) *R/W
(8-A7) *SRA WE

(8-4A) SND DB
(8-1A) SNO AB.

(8-6B) *SKO OE
(8-6B) DC 12
(7-6B) BDR2

(8-6B) BC:11
(8-6B) BDR1
(1-7B) *RST
(7-3E) SOUND CLK

SND LA (10-2E)
SND RA (10-5E)

SND LBC (10-3E)
SND RBC (10-6E)

第3巻法

記号	担当者	年月日	改訂	箇所	符号	部品	図面番号	名称	仕様	材質
								SOUND MEMORY and GENERATOR		
材料	承認	検印	検印	検印	検印	検印	検印	K-10668-1		

富士通株式会社

記事 *1 MB 5750 部材の代替は仕様の適用

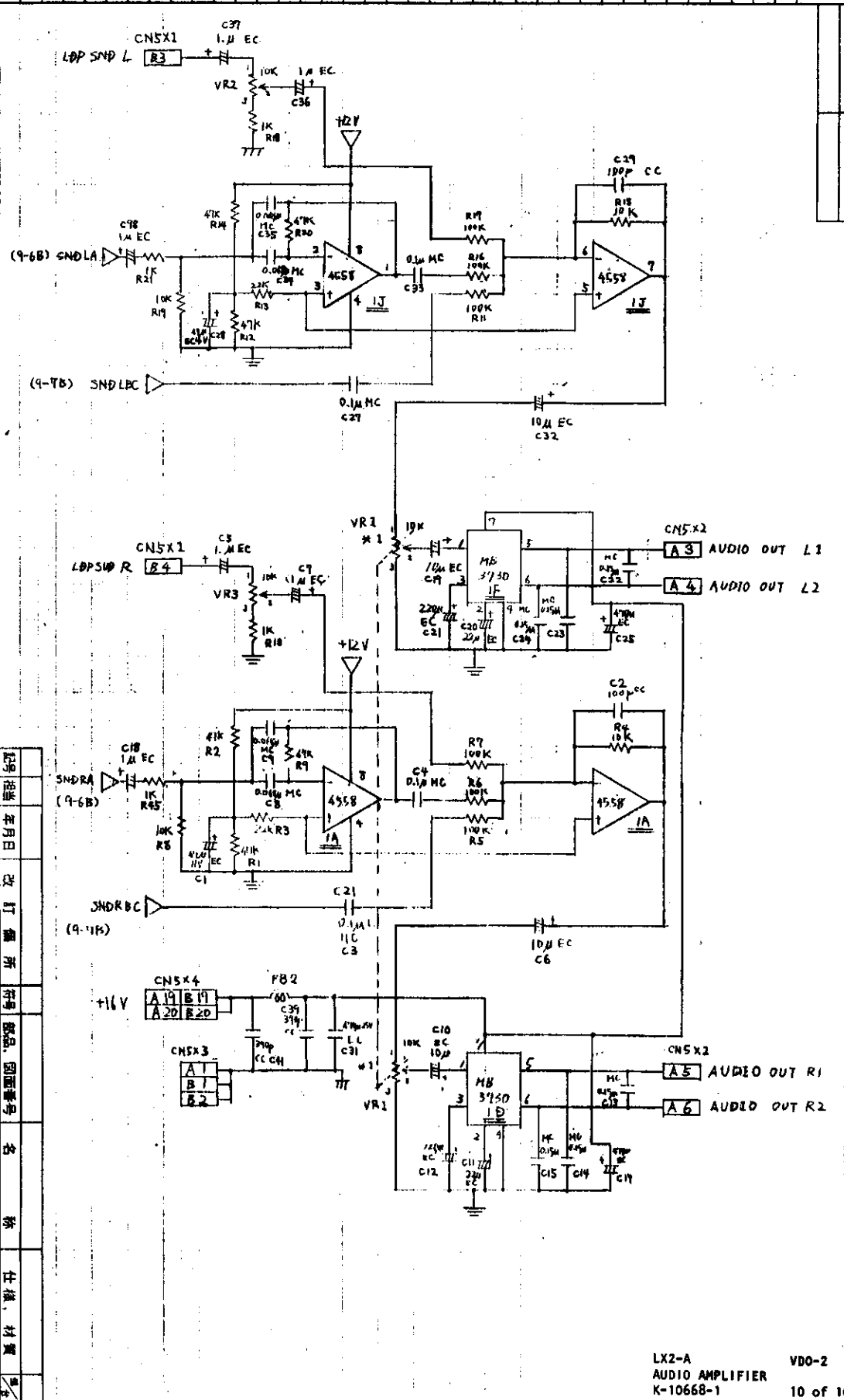

第3章 用法

承認 2/16	検出	検出	検出	検出	検出	検出	検出	検出	検出
材料	起号	年月日	改訂	場所	符号	部品	図面番号	名称	仕様、材質
								LX-2A VDO-2	AUDIO AMPLIFIER
								K-10668-1	

三菱電機株式会社